

5 Pin DIN
Female Connector

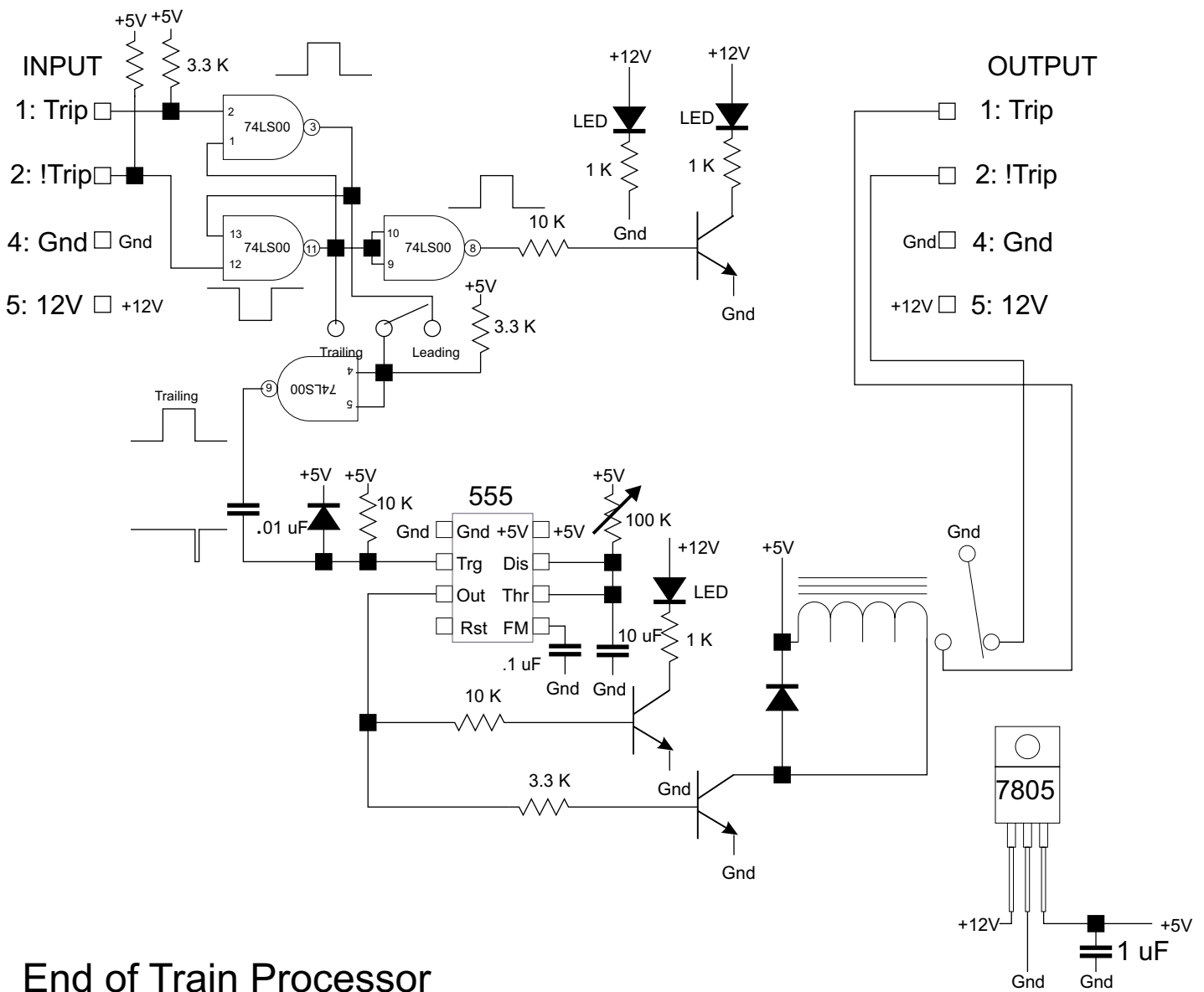
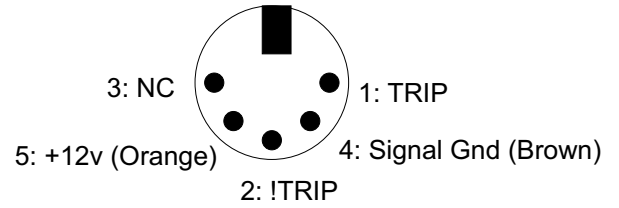

End of Train Processor Variant B

Norbert Doerry

March 31, 2001

Rev 1: May 11, 2001

End of Train Processor Variant B

Norbert Doerry

March 31, 2001

Rev 1: May 11, 2001

