

Reverse unit works on AC, DC, and AC/DC.

For universal (series wound) motors only

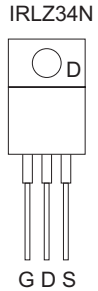

5 Pin DIN Female Connector

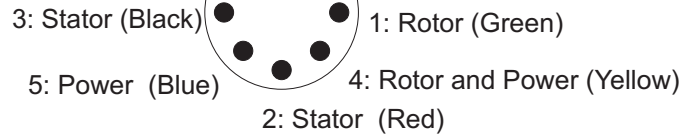

With switch in Auto mode train travels Forward when provided AC power or DC if the DPDT switch is pointed to the + rail Reverse when provided DC power and the DPDT switch is pointed to the - rail.

Forward: 5-2 and 1-3
Reverse: 5-3 and 1-2

Note: Diodes across S-D are part of Transistor Package

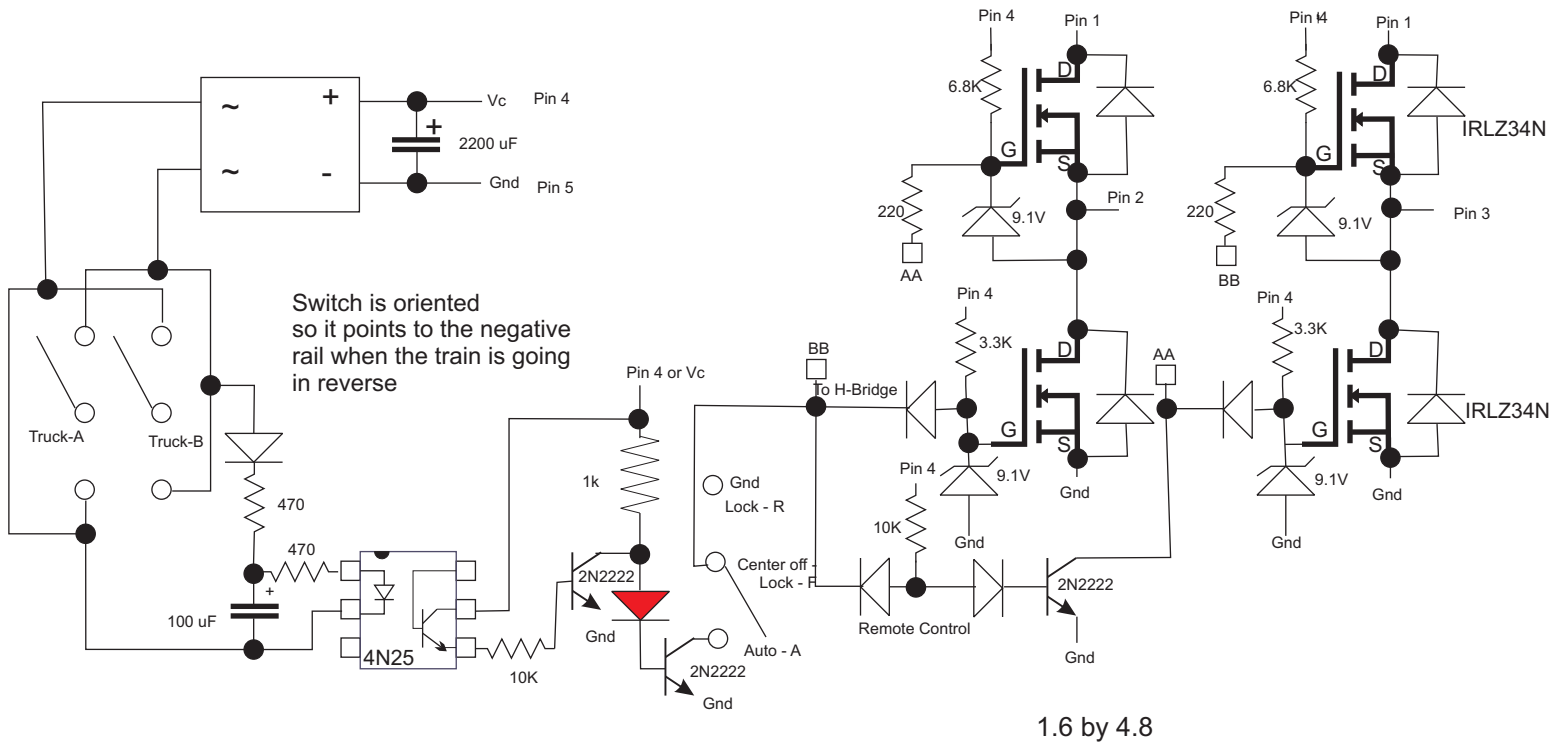

1.6 by 4.8

