

5 Pin DIN Female Connector

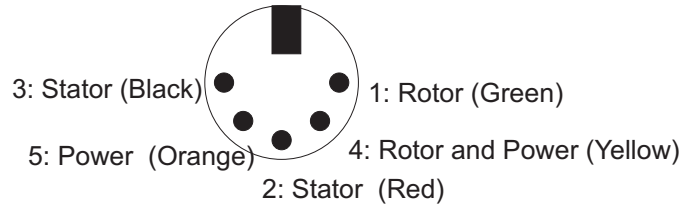

With switch in Auto mode train travels Forward when provided AC power Reverse when provided DC power

Forward: 5-2 and 1-3
Reverse: 5-3 and 1-2

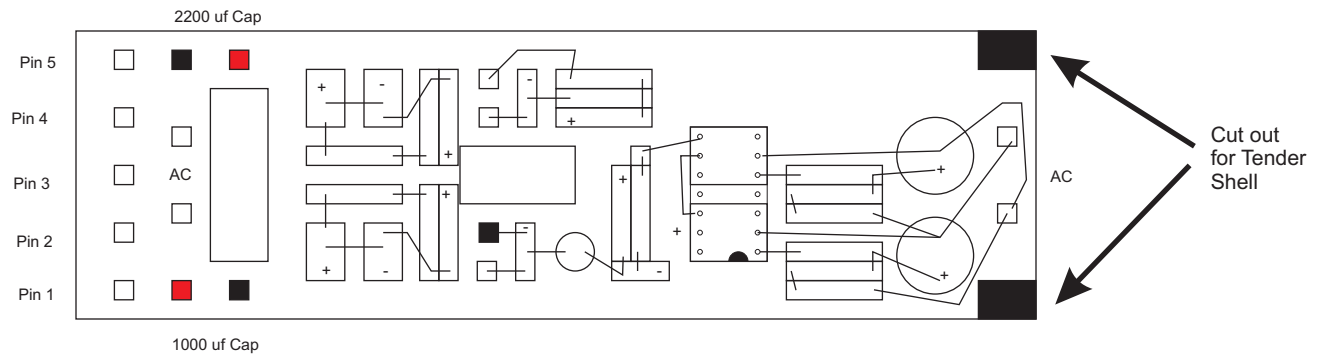
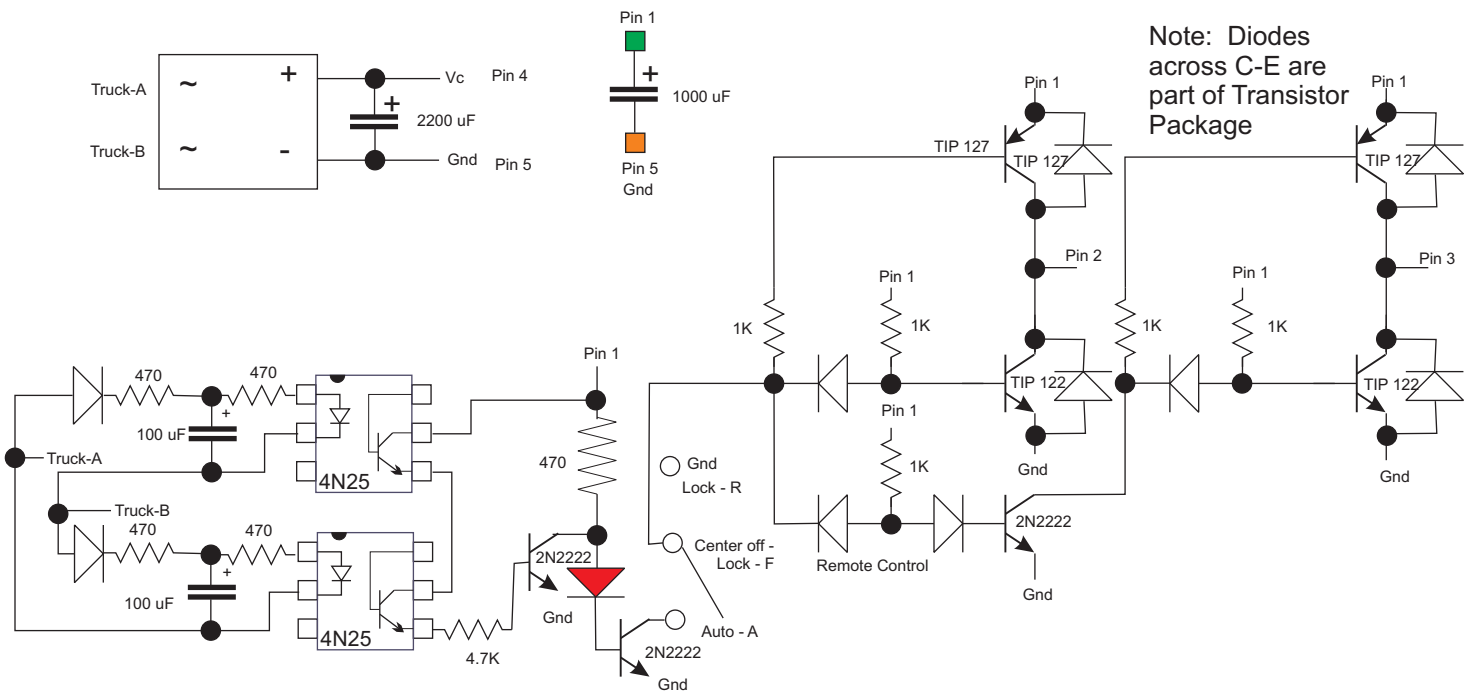

Transistor Based AC-DC Reversing Unit

Norbert Doerry
Sept-Oct 2011