

IRLZ34N

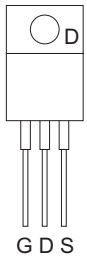

5 Pin DIN
Female Connector

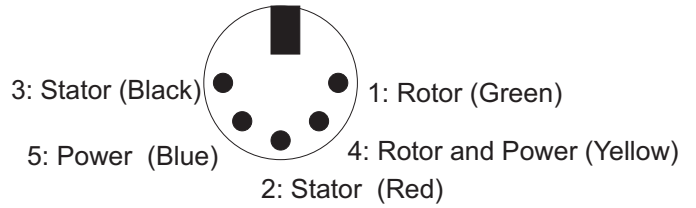

With switch in Auto mode train travels
Forward when provided AC power
Reverse when provided DC power

Forward: 5-2 and 1-3
Reverse: 5-3 and 1-2

Note: Diodes
across S-D are
part of Transistor
Package

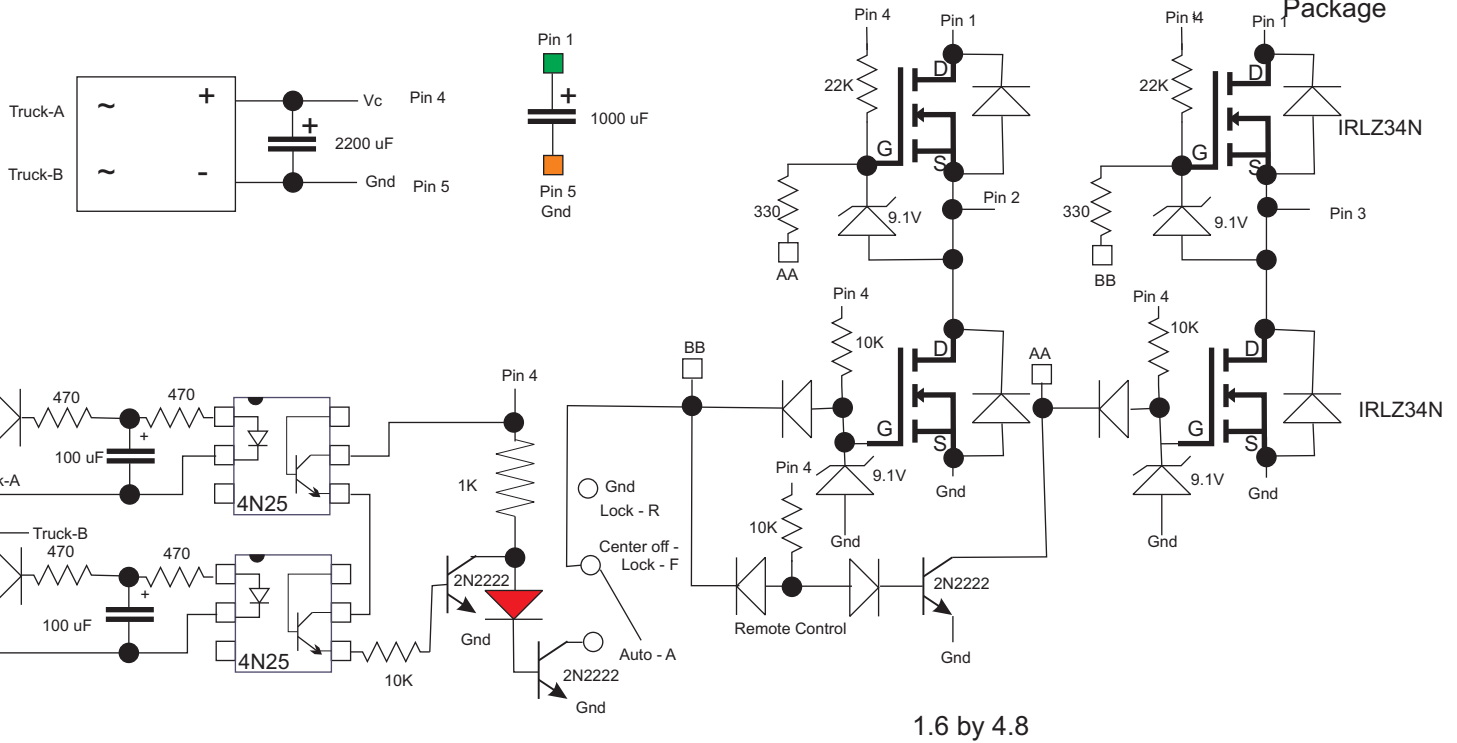

1.6 by 4.8

