

# RAILROAD CROSSING LIGHTS CONTROL CIRCUIT FOR AMERICAN FLYER 760 HIGHWAY FLASHER

Norbert Doerry  
 April 11, 2009  
 Rev A: May 3, 2009

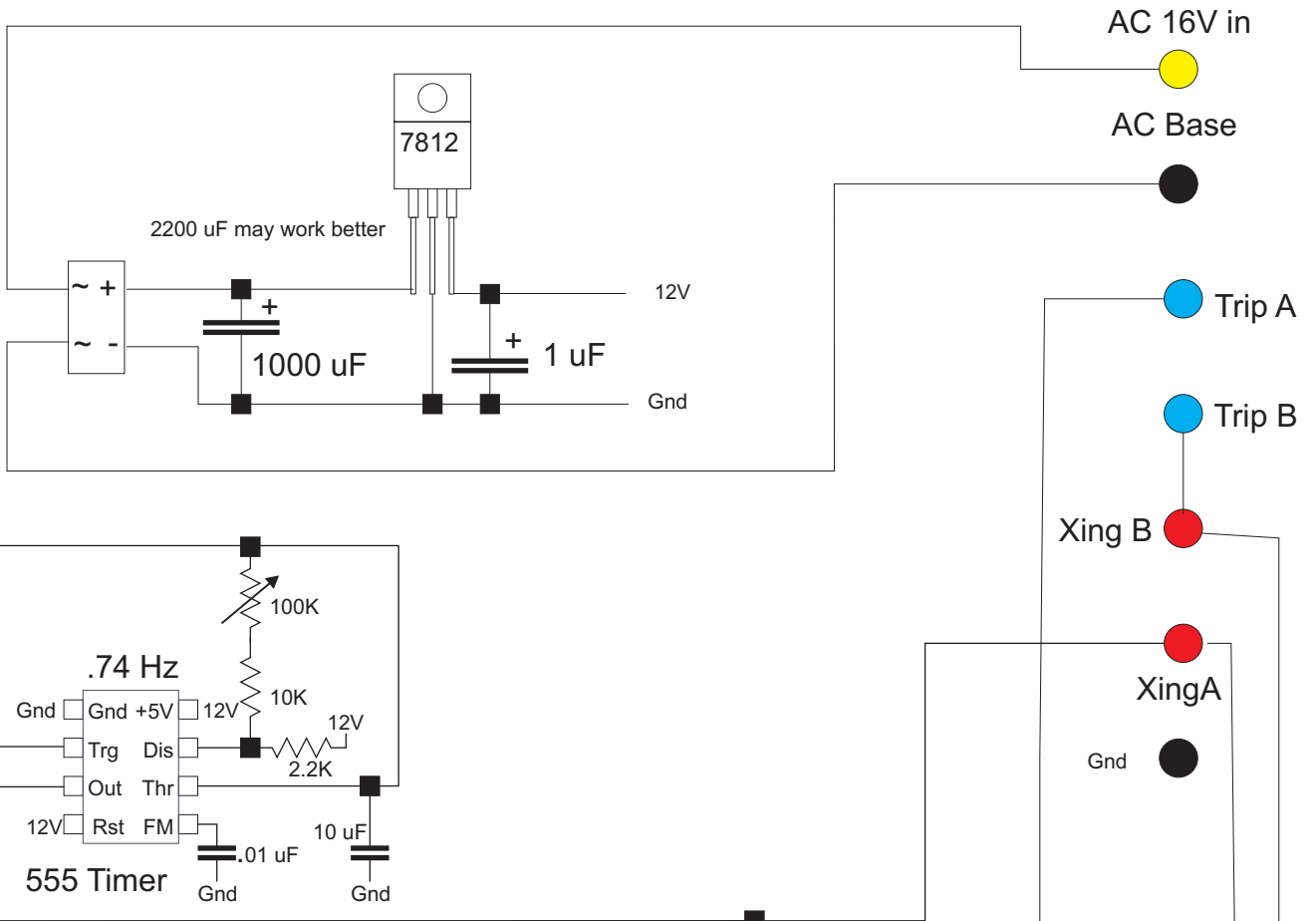

NOTE: Measurements at B&O Museum on June 24, 2002 indicate the clock should have a period of 1.35 seconds or 0.74 Hz. (27 seconds for 20 flashes)

For the Track Trip,  
 Use a 697 Pressure Trip  
 (Terminals 1 and 3)

Multiple trips can be connected  
 in parallel

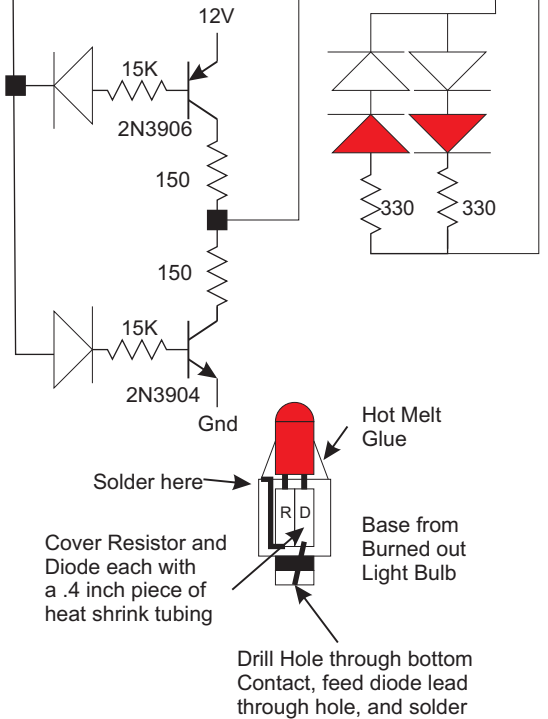

# RAILROAD CROSSING LIGHTS CONTROL CIRCUIT FOR AMERICAN FLYER 760 HIGHWAY FLASHER

Norbert Doerry  
April 11, 2009  
Rev A: May 3, 2009

