

9300
Ser 05T/002
16 January 2020



Preliminary Interface Standard Medium Voltage Electric Power, Direct Current

**Approved for Public Release
Distribution Unlimited**

*Naval Sea Systems Command
Technology Office (SEA 05T)
1333 Isaac Hull Ave SE
Washington Navy Yard DC 20376*



Preliminary Interface Standard Medium Voltage Electric Power, Direct Current

Prepared by:

A handwritten signature in blue ink, appearing to read "Norbert Doerry", is written over a horizontal line.

Dr. Norbert Doerry
Technical Director, NAVSEA Technology Office

A handwritten signature in blue ink, appearing to read "Humberto Lopez", is written over a horizontal line.

Humberto Lopez
Technical Warrant Holder, Machinery - Electrical Systems
Architecture, Control and Interface - Ships

A handwritten signature in blue ink, appearing to read "T.A. Barnard", is written over a horizontal line.

T.A. Barnard, Director
NAVSEA Technology Office (SEA 05T)

REPORT DOCUMENTATION PAGE

Form Approved
OMB No. 0704-0188

Public reporting burden for this collection of information is estimated to average 1 hour per response, including the time for reviewing instructions, searching existing data sources, gathering and maintaining the data needed, and completing and reviewing this collection of information. Send comments regarding this burden estimate or any other aspect of this collection of information, including suggestions for reducing this burden to Department of Defense, Washington Headquarters Services, Directorate for Information Operations and Reports (0704-0188), 1215 Jefferson Davis Highway, Suite 1204, Arlington, VA 22202-4302. Respondents should be aware that notwithstanding any other provision of law, no person shall be subject to any penalty for failing to comply with a collection of information if it does not display a currently valid OMB control number. **PLEASE DO NOT RETURN YOUR FORM TO THE ABOVE ADDRESS.**

1. REPORT DATE (DD-MM-YYYY) 16-01-2020		2. REPORT TYPE TECHNICAL		3. DATES COVERED (From - To) DEC 2018 - OCT 2019	
4. TITLE AND SUBTITLE Preliminary Interface Standard, Electric Power, Medium Voltage Direct Current				5a. CONTRACT NUMBER	
				5b. GRANT NUMBER	
				5c. PROGRAM ELEMENT NUMBER	
6. AUTHOR(S) Doerry, Norbert, H.				5d. PROJECT NUMBER	
				5e. TASK NUMBER	
				5f. WORK UNIT NUMBER	
7. PERFORMING ORGANIZATION NAME(S) AND ADDRESS(ES) Naval Sea Systems Command Technology Group (SEA 05T) 1333 Isaac Hull Ave SE Washington Navy Yard, DC 20376				8. PERFORMING ORGANIZATION REPORT NUMBER SEA 05T/002	
9. SPONSORING / MONITORING AGENCY NAME(S) AND ADDRESS(ES)				10. SPONSOR/MONITOR'S ACRONYM(S)	
				11. SPONSOR/MONITOR'S REPORT NUMBER(S)	
12. DISTRIBUTION / AVAILABILITY STATEMENT Approved for public release, distribution unlimited					
13. SUPPLEMENTARY NOTES					
14. ABSTRACT This manuscript documents the results of efforts to develop a Medium Voltage Direct Current (MVDC) interface standard for future naval surface warships.					
15. SUBJECT TERMS INTERFACE STANDARD, MEDIUM VOLTAGE DIRECT CURRENT, MVDC					
16. SECURITY CLASSIFICATION OF:			17. LIMITATION OF ABSTRACT UU	18. NUMBER OF PAGES 35	19a. NAME OF RESPONSIBLE PERSON Norbert Doerry
a. REPORT U	b. ABSTRACT U	c. THIS PAGE U			19b. TELEPHONE NUMBER (include area code) 202-781-2520

1. INTRODUCTION

The U.S. Navy is currently developing high power sensors, high power electronic warfare systems, solid state lasers (SSLs), and electromagnetic railguns (EMRG) as part of a revolution in ship self-defense and area-defense. With these new weapon systems, the U.S. Navy plans to counter the anti-access/area denial strategies of potential adversaries by greatly increasing the amount of ordnance each ship can carry, by achieving a favorable cost exchange ratio (the cost of shooting down a cruise missile/unmanned air vehicle (UAV) is less than the cost of the cruise missile/UAV), and by enabling our warships to operate where they need to in order to implement distributed lethality.

These new high power and pulsed loads present significant challenges to design of naval power systems. Their power characteristics can be stochastic or require high power ramp rates. With a traditional a.c. power system, a considerable amount of energy storage buffering, at great expense, is required to ensure the power system remains both small and large signal stable. An alternate approach, based on generating and distributing MVDC power (6 kV, 12 kV, or 18 kV) promises to enable affordable power systems that can support these advanced electric loads with higher power density than achievable with a.c. systems.

Because of the lack of interface standards for MVDC applications, efforts began in 2016 to develop a new MIL-STD-1399 section for MVDC. Early drafts were circulated within the Government and industry. In January 2019, a formal standards project was initiated. An intermediate review of the proposed standard was conducted during the summer of 2019 and all comments adjudicated. The draft standard with intermediate review comments adjudicated is provided as Appendix A.

Due to the lack of technical maturity (system, components) and lack of operational experience with MVDC systems, the Technical Warrant Holder (TWH) does not recommend MVDC for near term designs. The TWH concluded that development of an MVDC interface standard is premature and decided to put the MVDC interface standard development on hold until an immediate need is identified and objective quality evidence (OQE) presented to support implementation on a U.S. Navy platform. The TWH recommends leveraging ONR, NRL, and NSWCPD to further develop and quantify MVDC performance and benefits. Consequently, the TWH elected not to proceed to Standards Review Board (SRB) circulation.

2. GUIDANCE

Appendix A is suitable for use in non-acquisition projects for the purpose of further increasing the knowledge base for MVDC shipboard applications, to develop the OQE to support implementation on a U.S. Navy platform, and to enable future refinement of the interface standard. Appendix A shall not be used for acquisition programs for U.S. naval warships without prior approval and direction from the Technical Authority.

APPENDIX A: PRELIMINARY MVDC INTERFACE STANDARD

NOTE: This draft, dated 26 November 2019, prepared by Naval Sea Systems Command, has not been approved and is subject to modification. DO NOT USE PRIOR TO APPROVAL. (Project xxxx-xxxx-xxx)

METRIC

MIL-STD-1399

SECTION 300, PART 3

DRAFT

**DEPARTMENT OF DEFENSE
INTERFACE STANDARD**

SECTION 300, PART 3

**MEDIUM VOLTAGE ELECTRIC POWER,
DIRECT CURRENT**



FOREWORD

1. This standard is approved for use by all Departments and Agencies of the Department of Defense.
2. This part defines the standard interface requirements and verification methods for the design of shipboard sources and loads that will utilize shipboard direct current (DC) electric power above 1,000 volts. Sources are power conversion equipment within the electric power system. Loads are user equipment and power conversion equipment within the electric power system.
3. Comments, suggestions, or questions on this document should be addressed to Commander, Naval Sea Systems Command, ATTN: SEA 05S, 1333 Isaac Hull Avenue, SE, Stop 5160, Washington Navy Yard DC 20376-5160 or emailed to CommandStandards@navy.mil, with the subject line "Document Comment". Since contact information can change, you may want to verify the currency of this address information using the ASSIST Online database at <https://assist.dla.mil>.

CONTENTS

<u>PARAGRAPH</u>	<u>PAGE</u>
1. SCOPE.....	7
1.1 Scope	7
1.2 Classification	7
1.3 Electrical interface	7
2. APPLICABLE DOCUMENTS	8
2.1 General	8
2.2 Government documents	8
2.2.1 Specifications, standards, and handbooks	8
2.2.2 Other Government documents, drawings, and publications	8
2.3 Non-Government publications.....	8
2.4 Order of precedence.....	8
3. DEFINITIONS	9
3.1 Commanded reference voltage	9
3.2 Common mode current	9
3.3 Common mode impedance	9
3.4 Common mode voltage.....	9
3.5 Control negotiations.....	9
3.6 Current limiting period	9
3.7 Function normally.....	9
3.8 Inrush current.....	9
3.9 Load.....	9
3.10 Load abnormal service steady-state voltage range.....	9
3.11 Load change.....	9
3.12 Load maximum current pulse (control negotiation).....	9
3.13 Load maximum current pulse (no control negotiation).....	9
3.14 Load maximum current rate of change (control negotiation)	9
3.15 Load maximum current rate of change (no control negotiation)	9
3.16 Load maximum current ripple	10
3.17 Load maximum inrush current.....	10
3.18 Load maximum steady-state voltage ripple	10
3.19 Load normal service steady-state voltage range	10
3.20 Load peak current ripple	10
3.21 Load peak voltage ripple.....	10
3.22 Load voltage interruption tolerance time	10
3.23 Medium voltage direct current	10
3.24 Minimal current ripple	10

<u>PARAGRAPH</u>	<u>PAGE</u>
3.25 Minimal voltage ripple	10
3.26 Mission critical equipment.....	10
3.27 Neutral voltage	10
3.28 Nominal system voltage	10
3.29 Normal operating mode	10
3.30 Pulsed load.....	10
3.31 Rated current.....	10
3.32 Source	10
3.33 Source maximum current pulse (control negotiation).....	10
3.34 Source maximum current pulse (no control negotiation).....	10
3.35 Source maximum current rate of change (control negotiation).....	10
3.36 Source maximum current rate of change (no control negotiation).....	11
3.37 Source maximum current ripple.....	11
3.38 Source maximum steady-state current limit.....	11
3.39 Source maximum steady-state voltage ripple	11
3.40 Source peak voltage ripple.....	11
3.41 Source steady-state voltage range: 0 to rated power	11
3.42 Source steady-state voltage range: current limiting	11
3.43 Source steady-state voltage tolerance	11
3.44 Step load change	11
3.45 Technical Authority	11
3.46 Temperature stability	11
3.47 Voltage power quality.....	11
4. GENERAL REQUIREMENTS.....	11
4.1 Interface requirements	11
4.1.1 Loads	11
4.1.2 Sources.....	11
4.1.3 Equipment acting as both sources and loads.....	12
4.2 Nominal system voltage	12
4.3 Normal operating mode	12
4.4 Distribution equipment	12
4.5 Measurements	12
4.5.1 Measurement sampling rates.....	12
4.5.2 Measurement resolution.....	12
4.5.3 Steady-state measurements	12
4.5.4 Current rate of change measurements.....	12
4.5.5 Current pulse detection and measurement	12
4.5.6 Load change measurement.....	13

<u>PARAGRAPH</u>	<u>PAGE</u>
4.5.7 Frequency content measurements	13
4.6 Current ripple.....	13
4.7 Deviations.....	13
5. DETAILED REQUIREMENTS.....	13
5.1 Common requirements.....	13
5.1.1 Grounding.....	13
5.1.2 Pulsed current injection (PCI) generator.....	14
5.2 Load requirement.....	15
5.2.1 Load interface	15
5.2.2 Power interruptions.....	16
5.2.3 Current rate of change.....	16
5.2.4 Pulsed loads	16
5.2.5 Voltage spikes.....	16
5.2.6 EMP.....	16
5.2.7 Stability.....	16
5.2.8 Common mode impedance, voltage, and current.....	17
5.2.9 Maximum deviation from nominal system voltage	17
5.2.10 Maximum line-to-ground voltage	17
5.2.11 Load current.....	17
5.2.12 Load current ripple frequency content	17
5.3 Load verification methods	17
5.3.1 Load normal service test.....	17
5.3.2 Load abnormal service test	18
5.3.3 Load ground fault test.....	19
5.3.4 Load interruption tolerance test.....	19
5.3.5 Load voltage spike test	19
5.3.6 Pulsed load test.....	19
5.3.7 Load EMP test.....	20
5.4 Source requirements.....	20
5.4.1 Source interface	20
5.4.2 Source maximum current ripple.....	21
5.4.3 Current limiting	21
5.4.4 Inrush current and current overload capability	22
5.4.5 Current rate of change and pulse support.....	22
5.4.6 Voltage spikes.....	23
5.4.7 EMP protection.....	23
5.4.8 Stability.....	23
5.4.9 Common mode impedance, voltage, and current.....	23

<u>PARAGRAPH</u>	<u>PAGE</u>
5.4.10 Ground fault.....	23
5.4.11 Parallel operation.....	23
5.5 Source verification methods.....	23
5.5.1 Source voltage regulation test.....	24
5.5.2 Source current limit and inrush current test.....	24
5.5.3 Source ground fault test.....	25
5.5.4 Source voltage spike test.....	26
5.5.5 Source pulse test.....	26
5.5.6 Source EMP test.....	27
6. NOTES.....	27
6.1 Intended use.....	27
6.2 Acquisition requirements.....	27
6.3 Tailoring guidance for contractual application.....	28
6.4 Subject term (key word) listing.....	28
<u>FIGURES</u>	<u>PAGE</u>
FIGURE 1. DC interfaces.....	7
FIGURE 2. Short-circuit waveform.....	14
FIGURE 3. Generator Norton equivalent source.....	14
FIGURE 4. Source maximum inrush current.....	22
<u>TABLES</u>	<u>PAGE</u>
TABLE I. Nominal system voltages.....	7
TABLE II. Load interface characteristics.....	15
TABLE III. Load interface requirements.....	15
TABLE IV. Source interface characteristics.....	21
TABLE V. Source interface requirements.....	21

1. SCOPE

1.1 Scope. This military standard section establishes electrical interface characteristics for shipboard equipment utilizing or providing medium voltage direct current (MVDC) electric power above 1,000 volts to ensure compatibility between electrical sources and loads. Characteristics of the electrical interfaces, as well as interface requirements and interface verification methods for electrical sources and loads are provided. For equipment with multiple electrical power interfaces, this standard only applies to those interfaces utilizing MVDC.

1.2 Classification. This standard defines type I power quality requirements for nominal line-to-line voltages of shipboard MVDC electric power as listed in [table I](#). Type I power is intended for shipboard integrated power and energy systems where all sources and loads are power electronics based and the total installed generation capacity exceeds 10 megawatts. The use of type I power in other power systems is not precluded, but its use should be analyzed thoroughly to ensure applicability. Additional types may be defined in the future.

TABLE I. Nominal system voltages.

Nominal System Voltage	Class
6,000 VDC	Type I
12,000 VDC	Type I
18,000 VDC	Type I
NOTE: VDC = volts direct current	

1.3 Electrical interface. The basic characteristic and constraint categories concerned with this interface are shown symbolically on [figure 1](#). The source interface [1], as it concerns the characteristics of DC electric power, is located at the output terminals of the electric power source(s). The load interface [2], as it concerns the characteristics of DC electric power, is located at the input terminals of the electrical load(s).

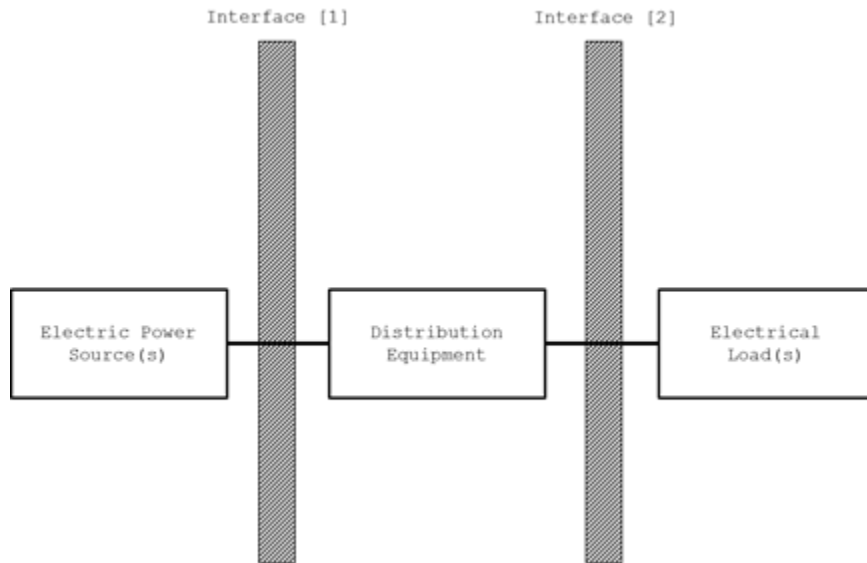

FIGURE 1. DC interfaces.

2. APPLICABLE DOCUMENTS

2.1 General. The documents listed in this section are specified in sections 3, 4, or 5 of this standard. This section does not include documents cited in other sections of this standard or recommended for additional information or as examples. While every effort has been made to ensure the completeness of this list, document users are cautioned that they must meet all specified requirements of documents cited in sections 3, 4, or 5 of this standard, whether or not they are listed.

2.2 Government documents.

2.2.1 Specifications, standards, and handbooks. The following specifications, standards, and handbooks form a part of this document to the extent specified herein. Unless otherwise specified, the issues of these documents are those cited in the solicitation or contract.

DEPARTMENT OF DEFENSE STANDARDS

- MIL-STD-461 - Requirements for the Control of Electromagnetic Interference Characteristics of Subsystems and Equipment
- MIL-STD-1310 - Shipboard Bonding, Grounding, and other Techniques for Electromagnetic Compatibility, Electromagnetic Pulse (EMP) Mitigation, and Safety
- MIL-STD-1399 - Interface Standard for Shipboard Systems

DEPARTMENT OF DEFENSE HANDBOOKS

- MIL-HDBK-2036 - Preparation of Electronic Equipment Specifications

(Copies of these documents are available online at <https://quicksearch.dla.mil/>.)

2.2.2 Other Government documents, drawings, and publications. The following other Government documents, drawings, and publications form a part of this document to the extent specified herein. Unless otherwise specified, the issues of these documents are those cited in the solicitation or contract.

NAVAL SEA SYSTEMS COMMAND (NAVSEA) PUBLICATIONS

- T9300-AF-PRO-020 - Electrical Systems Design Criteria and Practices (Surface Ships) for Preliminary and Contract Design

(Copies of this document are available online via Technical Data Management Information System (TDMIS) at <https://mercury.tdmis.navy.mil/>. Refer questions, inquiries, or problems to: DSN 296-0669, Commercial (805) 228-0669. This document is available for ordering (hard copy) via the Naval Logistics Library (NLL) at <https://nll.navsup.navy.mil/>. For questions regarding the NLL, contact the NLL Customer Service at nllhelpdesk@navy.mil, (866) 817-3130, or (215) 697-2626/DSN 442-2626.

2.3 Non-Government publications. The following documents form a part of this document to the extent specified herein. Unless otherwise specified, the issues of these documents are those cited in the solicitation or contract.

INTERNATIONAL ELECTROTECHNICAL COMMISSION (IEC)

- IEC 61000-4-5 - Electromagnetic Compatibility EMC – Part 4-5: Testing and Measurement Techniques – Surge Immunity Test

(Copies of this document are available online at www.iec.ch.)

2.4 Order of precedence. Unless otherwise noted herein or in the contract, in the event of a conflict between the text of this document and the references cited herein, the text of this document takes precedence. Nothing in this document, however, supersedes applicable laws and regulations unless a specific exemption has been obtained.

3. DEFINITIONS

3.1 Commanded reference voltage. The voltage set point, within the source steady-state voltage range (0 to rated power), to which a source regulates its output voltage. This set point is often a function of the steady-state current in the form of a droop characteristic.

3.2 Common mode current. The sum of the instantaneous currents of the positive and negative conductors out of the interface. The common mode current is typically depicted as a function of frequency. Common mode currents have return paths outside the set of conductors, typically through the ship's hull or cable shields.

3.3 Common mode impedance. The common mode impedance between two points is the common mode voltage divided by the common mode current. The common mode impedance is typically depicted as a function of frequency.

3.4 Common mode voltage. The neutral voltage referenced to the ground plane. The ground plane is typically the ship's hull. The common mode voltage is typically depicted as a function of frequency. Common mode voltages are often the result of circuit asymmetry and the choice of circuit topology and power electronics switching algorithms.

3.5 Control negotiations. Control interactions between loads or sources and the electric plant control system using a standard protocol that result in the establishment of limits for the behavior of the loads or sources. Generally applies to sources, large loads, and large pulse loads where the power system may require reconfiguration before the power needs of the load can be met.

3.6 Current limiting period. Period of time a source provides current while the bus voltage is in the source steady-state voltage range (current limiting).

3.7 Function normally. Operate in conformance with equipment specifications and with no increase in safety risk.

3.8 Inrush current. Load current that flows in the first 100 milliseconds after a load is energized. Inrush current is usually associated with the initial charging of filter capacitors and inductances.

3.9 Load. A consumer of power from the MVDC distribution equipment under normal operation. Does not include equipment that only draw power from the MVDC distribution equipment under fault conditions.

3.10 Load abnormal service steady-state voltage range. The range of steady-state DC voltage that, when applied to loads (with voltage ripple ranging from 0 to the source maximum steady-state voltage ripple), does not cause damage to the loads. Loads may lose functionality while the voltage remains in this range as long as the loss of functionality does not directly result in damage to other equipment or injury to personnel. Loads may be subjected to voltages in the load abnormal service steady-state voltage range during system start-up, equipment start-up, equipment shutdown, and as the result of power systems component failures.

3.11 Load change. The increase or decrease in DC steady-state current in successive measurement windows.

3.12 Load maximum current pulse (control negotiation). The maximum change in current magnitude of a pulsed load that can be negotiated between the load and the electric plant control system and to which the load limits itself.

3.13 Load maximum current pulse (no control negotiation). If a higher value has not been previously negotiated between the load and the electric plant control system, the maximum change in current magnitude of a pulsed load to which the load limits itself.

3.14 Load maximum current rate of change (control negotiation). The maximum rate of change of the current waveform for a load that can be negotiated between the load and the electric plant control system.

3.15 Load maximum current rate of change (no control negotiation). The maximum rate of change of the current waveform for a load if a larger value has not been pre-negotiated between the load and the electric plant control system.

3.16 Load maximum current ripple. The maximum root mean square (rms) magnitude of the steady-state non-DC component of the current waveform of a load measured over a specified time window.

3.17 Load maximum inrush current. The peak instantaneous current that flows upon energizing the load.

3.18 Load maximum steady-state voltage ripple. The maximum rms value of the non-DC component of the voltage measured over a specified time window at the input of a load.

3.19 Load normal service steady-state voltage range. The range of steady-state DC voltage that, when applied to loads (with the voltage ripple up to the source maximum steady-state voltage ripple), the loads are expected to function normally. This range accounts for possible voltage drop in the distribution system as well as the source steady-state voltage range.

3.20 Load peak current ripple. The maximum magnitude of the difference between the instantaneous current and the steady-state current measured at the input of a load

3.21 Load peak voltage ripple. The maximum magnitude of the difference between the instantaneous voltage and the steady-state voltage measured at the input of a load

3.22 Load voltage interruption tolerance time. The duration of power interruption (voltage within the load abnormal service steady-state voltage range) that a load can tolerate as specified and not be damaged.

3.23 Medium voltage direct current. DC voltages between 1,000 volts and 35,000 volts.

3.24 Minimal current ripple. Current ripple that is less than 20 percent of the load (or source) maximum current ripple (as applicable).

3.25 Minimal voltage ripple. Voltage ripple that is less than 20 percent of the load (or source) maximum steady-state voltage ripple (as applicable).

3.26 Mission critical equipment. Equipment that is part of mission critical systems and required to operate through emergency conditions (see T9300-AF-PRO-020).

3.27 Neutral voltage. Equal to the voltage potential midway between the potentials of positive and negative conductors with respect to a reference potential, typically ground.

3.28 Nominal system voltage. The design system DC voltage measured between the positive and negative conductors (line-line). Used as a reference for establishing the other power quality requirements.

3.29 Normal operating mode. A particular condition of a piece of equipment in which the equipment is fulfilling one of its desired functions.

3.30 Pulsed load. A current profile that includes either a positive or negative pulse and does not include inrush current. See 4.5.5 for the method of detecting positive or negative pulses.

3.31 Rated current. The rated maximum power of a load or source divided by the nominal system voltage.

3.32 Source. A provider of power to the MVDC distribution equipment under normal operation. Does not include equipment that only provide power to the MVDC distribution equipment under fault conditions.

3.33 Source maximum current pulse (control negotiation). The maximum change in current magnitude of a pulsed load that can be negotiated between the source and the electric plant control system and that the source can provide while maintaining power quality.

3.34 Source maximum current pulse (no control negotiation). If a higher value has not been previously negotiated between the source and the electric plant control system, the maximum change in current magnitude of a pulsed load that the source can provide while maintaining power quality.

3.35 Source maximum current rate of change (control negotiation). The maximum rate of change of the current waveform that can be negotiated between the source and electric plant control system and that the source can provide to loads while maintaining power quality.

3.36 Source maximum current rate of change (no control negotiation). If a higher value has not been previously negotiated between the source and the electric plant control system, the maximum rate of change of the current waveform that the source can provide to loads while maintaining power quality.

3.37 Source maximum current ripple. The maximum rms value of the non-DC component of the current measured at the output of an online source for which a source must be able to maintain voltage power quality.

3.38 Source maximum steady-state current limit. The maximum steady-state current that a source will provide.

3.39 Source maximum steady-state voltage ripple. The maximum rms value of the non-DC component of the voltage measured at the output of an online source.

3.40 Source peak voltage ripple. The maximum magnitude of the difference between the instantaneous voltage and the steady-state voltage measured at the output of an online source.

3.41 Source steady-state voltage range: 0 to rated power. The allowable variation in the system DC voltage measured at the output of an online source in normal droop operation mode, normal voltage regulation mode, and constant power mode. This range does not account for potential voltage loss in the distribution system.

3.42 Source steady-state voltage range: current limiting. The allowable variation in the system DC voltage measured at the output of an online source under current limit operation. Sources may operate in this region during initial MVDC bus energization, when load power demand exceeds source power capacity prior to load shedding, and during fault conditions.

3.43 Source steady-state voltage tolerance. The maximum deviation of the steady-state voltage measured at the output of an online source from the commanded reference voltage.

3.44 Step load change. A load change greater than 20 percent of the load's rated current.

3.45 Technical Authority. The Technical Authority has the authority, responsibility, and accountability to establish, monitor, and approve technical standards, tools, and processes in conformance to higher authority policy, requirements, architectures, and standards. Contact NAVSEA 05S for assistance with contacting the appropriate Technical Authority for U.S. Navy ships.

3.46 Temperature stability. Temperature stability is achieved when the variation between successive temperature measurements at the same location does not exceed 1 °C after 6 minutes. For equipment that is designed to operate within a temperature limit cycle (continuously varying between a lower and upper bound), temperature stability is achieved once the equipment is within 2 °C of the lower bound after the equipment has achieved within 2 °C of the upper bound.

3.47 Voltage power quality. Adherence to the voltage requirements of [table II](#) or [table III](#), as applicable.

4. GENERAL REQUIREMENTS

4.1 Interface requirements. The specific interface requirements and constraints established herein are mandatory and shall be adhered to regarding any aspect of shipboard electrical power systems or user equipment designs to which these requirements and constraints apply, including systems and equipment design, production, and installation. The policies and procedures established by MIL-STD-1399 are mandatory. This section and the basic standard are to be viewed as an integral single document for use in the design and testing of electric power systems and user equipment. MIL-HDBK-2036 may be used as a guide for tailoring of requirements.

4.1.1 Loads. Loads shall adhere to the interface requirements specified in 5.2. Loads shall be verified as specified (see 6.2) to adhere to the interface requirements through the verification methods in 5.3. For loads that have multiple applicable interfaces, the requirements specified in 5.2 shall apply to each interface individually irrespective of conditions at the other interfaces.

4.1.2 Sources. Sources shall adhere to the interface requirements specified in 5.4. Sources shall be verified as specified (see 6.2) to adhere to the interface requirements through the verification methods in 5.5. For sources that have multiple applicable interfaces, the requirements specified in 5.4 shall apply to each interface individually irrespective of conditions at the other interfaces.

4.1.3 Equipment acting as both sources and loads. Some equipment, such as energy storage modules, may have power interfaces that sometimes act as sources and at other times act as loads. When acting as a source, the source interface requirements shall apply. When acting as a load, the load interface requirements shall apply.

4.2 Nominal system voltage. The nominal system voltage shall be as specified (see 6.2).

4.3 Normal operating mode. The normal operating modes shall be as specified (see 6.2).

4.4 Distribution equipment. The design of the distribution equipment on [figure 1](#) is governed by T9300-AF-PRO-020. The impedance, switching, transient surge suppression, electromagnetic pulse (EMP) protection, and fault clearing capability of the distribution equipment shall be designed to ensure that if sources and loads adhere to this standard, then the current characteristics at the source interface will also adhere to this standard. Similarly, if the sources and loads adhere to this standard, then the voltage characteristics at the load interfaces will also adhere to this standard.

4.5 Measurements. Unless otherwise specified (see 6.2), the following methods shall be used to evaluate compliance of voltage and current properties with this standard.

4.5.1 Measurement sampling rates. For all measurements, except for common mode currents and voltages, the sampling rate shall be constant and equal to or greater than the maximum of:

- a. 10 kilohertz.
- b. (in units of kilohertz) 0.1 (1/ampere) times the maximum current rate of change requirement measured in amperes per millisecond (A/ms).
- c. 20 times the effective power electronics switching frequency observable at the interface.

The sampling rate for common mode currents and voltages shall be as specified (see 6.2).

4.5.2 Measurement resolution. For all measurements, the analog to digital converter and associated measurement probes shall have a combined effective resolution equal to or greater than 16 bits and sufficient to measure current or voltage waveforms with an accuracy within 0.1 percent of the rated current for current measurements and within 0.1 percent of nominal system voltage for voltage measurements.

4.5.3 Steady-state measurements. The steady-state DC component for a voltage or current waveform shall be calculated as the average value over a 200 ± 1 -millisecond moving time window centered at each measurement. Steady-state ripple for a voltage or current waveform shall be calculated as the rms value of the difference between the waveform and the steady-state DC component over a 200 ± 1 -millisecond time window centered at each measurement.

4.5.4 Current rate of change measurements. The current rate of change shall be calculated by first applying a median filter to the sampled current data with a 10- to 20-millisecond window centered at each measurement, and then, for each point of the filtered data, determining the slope through linear regression of the samples over a sub-window centered on the point. The sub-window shall be of a duration of 1 ± 0.05 milliseconds for equipment with a load (or source) maximum current rate of change requirement equal to or less than 100 A/ms. For equipment with a load (or source) maximum current rate of change requirement greater than 100 A/ms, the sub-window (milliseconds) shall be of duration (ampere) divided by the load (or source) maximum current rate of change (A/ms) requirement with a tolerance of ± 5 percent. The median filter window size may be adjusted within its allowable range to minimize the impact of a dominant frequency component of the ripple.

4.5.5 Current pulse detection and measurement. A current pulse shall be detected and its magnitude calculated in the following manner:

- a. Apply a median filter with a 20 ± 0.2 -millisecond window to the current waveform samples.
- b. Subdivide a 3 ± 0.01 -second window into a series of 5 ± 0.1 -millisecond sub-windows.
- c. Calculate the average value for each sub-window.

d. Determine if a positive pulse is detected. A positive pulse is detected if the sub-window with the largest average has an average at least 100 amperes greater than the average of the sub-window with the smallest average before it and at least 100 amperes greater than the average of the sub-window with the smallest average after it. The start of the pulse is the beginning of the sub-window with the smallest average before the sub-window with the largest average and the end of the pulse is the end of the sub-window with the smallest average after the sub-window with the largest average.

e. Determine if a negative pulse is detected. A negative pulse is detected if the sub-window with the smallest average has an average at least 100 amperes less than the average of the sub-window with the largest average before it and at least 100 amperes less than the average of the sub-window with the largest average after it. The start of the pulse is the beginning of the sub-window with the largest average before the sub-window with the smallest average and the end of the pulse is the end of the sub-window with the largest average after the sub-window with the smallest average.

f. If a pulse is detected, its magnitude is the difference between the largest sub-window average and the smallest sub-window average.

g. Repeat b through f for successive 3-second windows. The time interval between the starts of successive 3-second windows shall not exceed 5 ± 0.1 milliseconds.

4.5.6 Load change measurement. A load change shall be calculated by taking the absolute value of the difference between the DC components of the current in the first half and the second half of a 200 ± 1 -millisecond time window centered on each measurement.

4.5.7 Frequency content measurements. The frequency content of current ripple shall be calculated using window sizes equal to the steady-state measurement time windows. The start of successive windows shall occur at intervals equal to 25 percent of the steady-state measurement time window. Zero padding may be employed to facilitate Fast Fourier Transform (FFT) calculations.

4.6 Current ripple. Current ripple and current ripple frequency limits shall not be applicable during steady-state measurement time windows (see 4.5.3) that include inrush current, current pulses, or the center of the 200-millisecond window for step load changes. Current ripple and current ripple frequency limits shall also not apply during equipment start-up and shutdown if the number of equipment start-ups and shutdowns combined does not exceed six per hour on average.

4.7 Deviations. The interfaces in this standard are based on a power electronics-based DC electric power system. To meet the intent of this section for non-traditional electric power systems or custom load interfaces, deviation of requirements will be considered. The deviation provisions in MIL-STD-1399 shall be adhered to during the early development stage of equipment as specified (see 6.2). Equipment requiring a deviation shall have an approved deviation. Requests for deviation shall be submitted for approval by the Technical Authority.

(NOTE: The Technical Authority is not required to approve deviations, but if a deviation is required, the equipment shall have an approved deviation by the Technical Authority or the equipment is not acceptable as designed.)

5. DETAILED REQUIREMENTS

5.1 Common requirements.

5.1.1 Grounding.

a. System grounding. Under normal operation, the power system steady-state neutral voltage with respect to the ground potential shall be between ± 1 percent of the nominal system voltage. A 1-kilovolt power system is implemented as ± 500 volts with respect to ground. Distribution system, source, and load equipment may include grounding networks to limit common mode current and establish a high resistance path between current carrying components and ground to limit fault currents. Refer to T9300-AF-PRO-020 and equipment specifications for grounding network requirements.

b. Ground faults. Ground faults between a power conductor and the ground potential shall normally be detected and cleared within 10 seconds by the distribution system. On rare occasions, such as during battle, the crew may elect to continue operating with a single ground fault for a prolonged period of time lasting up to several hours. Sources and loads shall be designed to achieve their service life when exposed to ground faults for an average of 2 hours each year.

c. Equipment grounding. Sources and loads shall implement equipment grounding in accordance with MIL-STD-1310 to contribute to electromagnetic compatibility, EMP mitigation, and safety. Equipment grounding establishes a low impedance connection between non-current carrying metallic parts and the ground potential.

5.1.2 Pulsed current injection (PCI) generator. A PCI generator produces the PCI waveform depicted on [figure 2](#) for the purpose of verifying robustness to EMPs. Rise time (τ_R) is measured from 10 percent to 90 percent of the peak value and shall be less than 2×10^{-8} seconds. Full-width at the half-maximum amplitude (FWHM) is the time interval between the 50-percent peak amplitude points and shall be between 5×10^{-7} and 5.5×10^{-7} seconds. As shown on [figure 3](#), a PCI generator is specified in terms of a current source in parallel with a source impedance (Norton equivalent source). Peak short-circuit current is the peak time-domain current of the PCI waveform into a short-circuit calibration load at the PCI pulse generator output terminals. Source impedance (R_{PCI}) is the PCI generator open-circuit peak time-domain voltage divided by the peak short-circuit current.

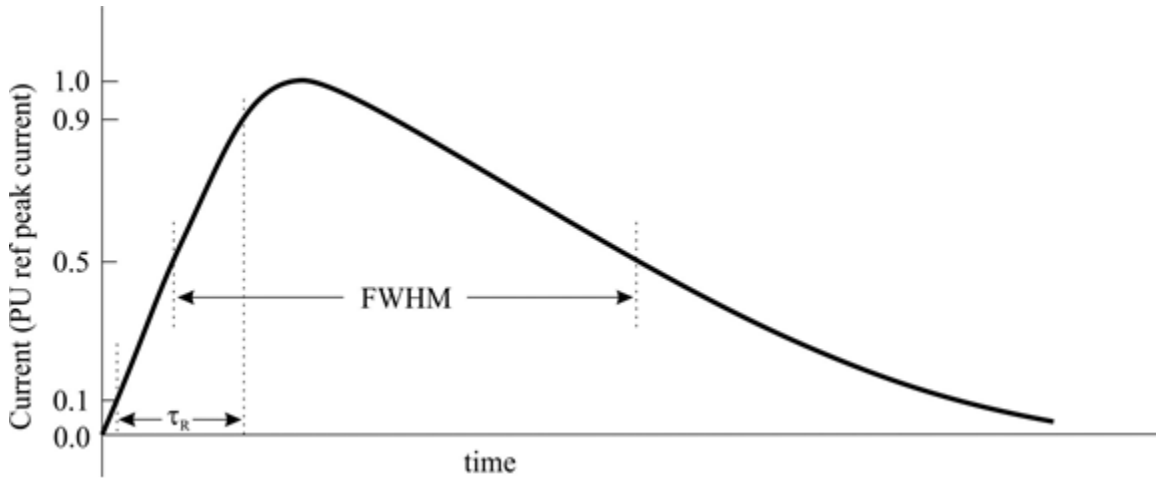

FIGURE 2. Short-circuit waveform.

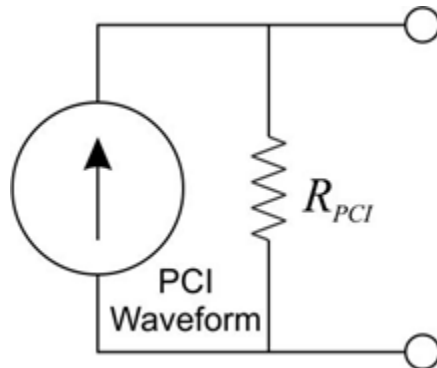

FIGURE 3. Generator Norton equivalent source.

5.2 Load requirement.

5.2.1 Load interface. Load interface characteristics and verification methods for demonstrating load operability to the interface characteristics shall be as specified in [table II](#). Load interface requirements and verification methods shall be as specified in [table III](#).

TABLE II. Load interface characteristics.

Characteristic	Value: Type I	Verification Method
Nominal system voltage (VDC)	6,000 12,000 18,000	N/A
Load normal service steady-state voltage range (percent of nominal system voltage)	84% to 106%	5.3.1
Load abnormal service steady-state voltage ranges (percent of nominal system voltage)	0% to 84% 106% to 110%	5.3.2
Load maximum steady-state voltage ripple (rms percent of nominal system voltage)	5%	5.3.1
Load peak voltage ripple (percent of nominal system voltage)	10.0%	5.3.1
Load voltage interruption tolerance time (ms)	120	5.3.4

TABLE III. Load interface requirements.

Characteristic	Value: Type I	Verification Method
Load maximum current ripple (percent of rated current)	10%	5.3.1
Load peak current ripple (percent of rated current)	30%	5.3.1
Load maximum inrush current	300% of rated current for loads with rated current ≤ 50 A 180 A for loads with $50 \text{ A} < \text{rated current} \leq 150$ A 120% of rated current for loads with rated current > 150 A	5.3.1
Load maximum current pulse (no control negotiation) (A)	See 5.2.4	5.3.6
Load maximum current rate of change (no control negotiation) (A/ms)	See 5.2.3	5.3.6
Load maximum current pulse (control negotiation) (A)	See 5.2.4	5.3.6
Load maximum current rate of change (control negotiation) (A/ms)	See 5.2.3	5.3.6

5.2.2 Power interruptions. When specified (see 6.2) and if the distribution system is capable of detecting, localizing, and isolating faults and restoring power to undamaged and unfaulted portions of the distribution system in less time than the value specified in [table II](#), then a value equal to 110 percent of the time required from the start of a fault until power has been restored may be used for the load voltage interruption tolerance time in lieu of the value in [table II](#).

a. Mission critical equipment (MCE). Unless otherwise specified (see 6.2), equipment designated as MCE shall operate through power interruptions of duration up to the load voltage interruption tolerance time without damage or operational interruption, without any loss of data, and without a restart or reboot. When specified (see 6.2), MCE may operate in a designated low power mode during the power interruption. Equipment designated as MCE shall not be damaged due to power interruptions of duration greater than the load voltage interruption tolerance time and shall restart without operator intervention after the restoration of power.

b. Loads not designated as MCE. Loads not designated as MCE may require a manual restart but shall not be damaged due to power interruptions of any duration.

5.2.3 Current rate of change.

a. Unless otherwise specified (see 6.2), the load maximum current rate of change (no control negotiation) shall be 50 A/ms.

b. Unless otherwise specified (see 6.2), the load maximum current rate of change (control negotiation) shall be 500 A/ms.

c. Loads that do not exceed the load maximum current rate of change (no control negotiation) are not required to negotiate the maximum current rate of change with the electrical power system control system.

d. Loads that never exceed the load maximum current rate of change (no control negotiation) are not required to implement protocols for negotiating the load maximum current rate of change; the load maximum current rate of change (control negotiation) does not apply.

e. Before exceeding the load maximum current rate of change (no control negotiation), loads shall negotiate a load maximum current rate of change that shall not exceed the load maximum current rate of change (control negotiation) with the electrical power system control system. The load shall not exceed the negotiated load maximum current rate of change.

5.2.4 Pulsed loads.

a. The load maximum current pulse (no control negotiation) shall be as specified (see 6.2).

b. The load maximum current pulse (control negotiation) shall be as specified (see 6.2).

c. Loads that do not exceed the load maximum current pulse (no control negotiation) are not required to negotiate the maximum current pulse with the electrical power system control system.

d. Loads that never exceed the load maximum current pulse (no control negotiation) are not required to implement protocols for negotiating the load maximum current pulse; the load maximum current pulse (control negotiation) does not apply.

e. Before exceeding the load maximum current pulse (no control negotiation), loads shall negotiate a load maximum current pulse that shall not exceed the load maximum current pulse (control negotiation) with the electrical power system control system. The load shall not exceed the negotiated load maximum current pulse.

5.2.5 Voltage spikes. Loads shall remain undamaged, shall not suffer any loss of data, shall not require a restart or reboot, and shall remain fully operational before, during, and after being subjected to voltage spikes in accordance with IEC 61000-4-5 using a test level 4 with a 1.2/50-microsecond combination wave generator. See 5.3.5 for the verification method.

5.2.6 EMP. Loads shall remain undamaged, shall not suffer any data loss, shall not require a restart or reboot, and shall remain fully operational before, during, and after being subjected to line-to-ground current pulses from a PCI generator with a waveform specified in 5.1.2, a peak short-circuit current of at least 500 amperes, and a source impedance of at least 60 ohms. See 5.3.7 for the verification method.

5.2.7 Stability. The requirements for small-signal and large-signal stability shall be as specified (see 6.2).

5.2.8 Common mode impedance, voltage, and current. Requirements for common mode impedances and requirements for limiting common mode voltages and currents shall be as specified (see 6.2).

5.2.9 Maximum deviation from nominal system voltage. The maximum positive deviation of the line-to-line voltage from the nominal system voltage (not including voltage spikes) is equal to the sum of the upper limit of the load normal service steady-state voltage percentage and the peak voltage ripple percentage minus 100 percent. Similarly, the maximum negative deviation of the line-to-line voltage from the nominal system voltage (not including voltage spikes) is equal to 100 percent minus the sum of the lower limit percentage of the load normal service steady-state voltage percentage and the peak voltage ripple percentage. Loads shall function normally within the maximum positive and maximum negative deviation of the line-to-line voltage.

5.2.10 Maximum line-to-ground voltage. The maximum line-to-ground magnitude occurs when one of the conductors is faulted to ground. The unfaulted conductor's maximum voltage magnitude (not including voltage spikes) with respect to ground equals the maximum positive deviation of the line-to-line voltage from the nominal system voltage plus the nominal system voltage. For a ground fault on the negative conductor, the maximum line-to-ground voltage on the positive conductor will be a positive voltage. For a ground fault on the positive conductor, the maximum line-to-ground voltage on the negative conductor will be a negative voltage. Loads shall remain undamaged, shall not suffer any data loss, shall not require a restart or reboot, and shall remain fully operational before, during, and after being subjected to line-to-ground faults. See 5.3.3 for the verification method.

5.2.11 Load current. After start-up of a load (not to exceed 100 milliseconds) during which the load maximum inrush current applies, the steady-state load current shall not exceed the rated power of the load divided by the steady-state voltage.

5.2.12 Load current ripple frequency content. The frequency content of the load current ripple shall not exceed:

- a. For steady-state DC load currents below 185 amperes and frequencies at or below 10 kilohertz, the CE101 limit for surface ships and submarine applications (DC) as specified in MIL-STD-461.
- b. Unless otherwise specified (see 6.2) for steady-state DC load currents at or above 185 amperes and frequencies at or below 10 kilohertz, the CE-101 limit for surface ships and submarine applications (DC) as specified in MIL-STD-461 for a load current of 3 amperes relaxed by $20\log(I/3)$ where I is the steady-state DC load current.
- c. For frequency components above 10 kilohertz, 0.2 percent of the steady-state DC component of the load current.

5.3 Load verification methods. This section provides load verification procedures to verify compliance to the load interface requirements specified in this standard. For loads verified through testing, the hardware and software of an equipment under test (EUT) shall be representative of production units. When specified (see 6.2), the verification/test procedure and verification/test report shall be subject to approval by the Technical Authority and the requirements within the verification/test procedure may be tailored as approved by the Technical Authority. Voltage and current measurements shall be in accordance with 4.5. The pulsed load test shall only be performed when specified (see 6.2).

5.3.1 Load normal service test. A load's performance shall be verified through testing when provided steady-state power having a steady-state voltage within the range specified in [table II](#) for load normal service steady-state voltage range.

- a. Apparatus. The following apparatus is recommended for performing this test:
 - (1) Power source(s) able to achieve required capacity, specified voltage ripple, and range of voltage adjustment.
 - (2) Temperature meter with ± 0.5 °C or better accuracy.
 - (3) Data acquisition system capable of capturing the voltage waveform, voltage measurement, voltage ripple measurement, current waveform, current measurement, and current ripple measurement. Measurements shall meet the sampling frequency and accuracy requirements of 4.5.

b. Procedure. The EUT shall be operated in all normal operating modes after power has been applied and the EUT has achieved temperature stability for the following test cases:

- (1) From powered down condition, apply nominal system voltage ± 1 percent, minimal voltage ripple.
- (2) Apply upper limit of the load normal service steady-state voltage range (or greater), minimal voltage ripple.
- (3) Apply lower limit of the load normal service steady-state voltage range (or less), minimal voltage ripple.
- (4) Apply nominal system voltage ± 1 percent, voltage ripple set at or greater than the load maximum steady-state voltage ripple.
- (5) Apply upper limit of the load normal service steady-state voltage range (or greater), voltage ripple set at or greater than load maximum steady-state voltage ripple.
- (6) Apply lower limit of the load normal service steady-state voltage range (or less), voltage ripple set at or greater than load maximum steady-state voltage ripple.

Unless otherwise specified (see 6.2), for test cases (4), (5), and (6) above, the voltage ripple shall consist of a periodic waveform with a fundamental frequency of $1,000 \pm 100$ hertz.

Voltage and current inrush waveforms shall be measured and recorded upon energizing the EUT from a powered down condition until the inrush current has subsided.

Once temperature stability has been achieved in each test case, voltage, voltage ripple, current, current ripple, frequency content of the current ripple, and internal equipment temperatures shall be measured and recorded in measurement windows of at least 6 seconds in duration at a maximum of 1-minute intervals for at least 5 minutes in each normal operating mode. The frequency content of the voltage and current ripple shall either be directly measured or calculated from the waveforms. For each normal operating mode, the EUT shall be verified to function normally.

5.3.2 Load abnormal service test. A load's performance shall be verified through testing when provided steady-state power having a steady-state voltage within the ranges specified in [table II](#) for load abnormal service steady-state voltage range.

- a. Apparatus. The following apparatus is recommended for performing this test:
- (1) Power source(s) able to achieve required capacity, specified voltage ripple, and range of voltage adjustment.
 - (2) Temperature meter with ± 0.5 °C or better accuracy.
 - (3) Data acquisition system capable of capturing the voltage waveform, voltage measurement, voltage ripple measurement, current waveform, current measurement, and current ripple measurement. Measurements shall meet the sampling frequency and accuracy requirements of 4.5.

b. Procedure. The EUT shall be energized for a period of not less than 5 minutes for each of the following test cases:

- (1) Apply between 8 and 12 percent of nominal system voltage, minimal voltage ripple.
- (2) Apply between 48 and 52 percent of nominal system voltage, minimal voltage ripple.
- (3) Apply between 78 and 82 percent of nominal system voltage, minimal voltage ripple.
- (4) Apply between 110 and 114 percent of nominal system voltage, minimal voltage ripple.

For each test case, voltage, voltage ripple, current, current ripple, frequency content of the current ripple, and internal equipment temperatures shall be measured and recorded in measurement windows of at least 6 seconds in duration at a maximum of 1-minute intervals for at least 5 minutes. The EUT shall be verified to not have sustained damage, caused damage to other equipment, or created a hazardous condition for personnel.

Following completion of the above test cases, nominal system voltage ± 1 percent shall be applied. Once the EUT has achieved temperature stability, the EUT shall be operated in all normal operating modes and verified to function normally.

5.3.3 Load ground fault test. A load's performance shall be verified through testing when provided steady-state power having a steady-state voltage within the range specified in [table II](#) for load normal service steady-state voltage range and with one of the two conductors at ground potential.

a. Apparatus. The following apparatus is recommended for performing this test:

(1) Power source(s) able to achieve required capacity and range of voltage adjustment. The power source shall have a high impedance (greater than 1 megaohm) between its output conductors and ground.

(2) Temperature meter with ± 0.5 °C or better accuracy.

(3) Single pole fused switch for each conductor. The fuse shall be capable of clearing the maximum line-to-line fault current (in case a low impedance already exists within the load between the power system and ground).

(4) Data acquisition system capable of capturing the voltage waveform, voltage measurement, voltage ripple measurement, current waveform, current measurement, and current ripple measurement. Measurements shall meet the sampling frequency and accuracy requirements of 4.5.

b. Procedure. The EUT shall be operated in all normal operating modes with the upper limit of the load normal service steady-state voltage (or greater) for the following test cases:

(1) Positive conductor grounded through the single pole fused switch.

(2) Negative conductor grounded through the single pole fused switch.

For each test case, prior to the start of each test case, the EUT shall be operated without the conductor grounded until the EUT has achieved temperature stability. At the start of the test case when the single pole fused switch is closed for the appropriate conductor, the line-to-line voltage, line-to-ground voltage for each conductor, voltage ripple, current in each conductor, current ripple in each conductor, common-mode current, frequency content of the current ripple, and internal equipment temperatures shall be measured and recorded for 400 milliseconds and then in measurement windows of at least 6 seconds in duration at a maximum of 1-minute intervals for at least 5 minutes. The frequency content of the voltage and current ripple shall either be directly measured or calculated from the waveforms. The ground shall then be removed and the test case repeated for each normal operating mode. During testing, the EUT shall be verified to function normally. The EUT fails the test if the fuse associated with one of the fused switches blows.

5.3.4 Load interruption tolerance test.

a. Apparatus. The following apparatus is recommended for performing this test:

(1) Power source able to achieve required capability, range of voltage adjustment, and programmability to create power interruptions of specified duration.

(2) Data acquisition system capable of capturing the voltage waveform, voltage measurement, voltage ripple measurement, current waveform, current measurement, and current ripple measurement. Measurements shall meet the sampling frequency and accuracy requirements of 4.5.

(3) Temperature meter with ± 0.5 °C or better accuracy.

b. Procedure. The EUT shall be operated in the following manner for all normal operating modes. Temperatures, duration of power interruption, whether the EUT functions in accordance with 5.2.2, and voltage and current waveforms shall be recorded for at least a 500-millisecond period centered on the interruption time period.

(1) Supply the EUT with the nominal system voltage ± 1 percent.

(2) Wait until the EUT has achieved temperature stability.

(3) Interrupt the power for a duration between 1 and 1.1 times the load voltage interruption tolerance time.

(4) Resume supplying the EUT with the nominal system voltage ± 1 percent.

(5) Verify that the EUT functions in accordance with 5.2.2.

5.3.5 Load voltage spike test. The load voltage spike test shall be conducted in accordance with the surge immunity test of IEC 61000-4-5 using the test level and wave generator specified in 5.2.5.

5.3.6 Pulsed load test.

a. Apparatus. The following apparatus is recommended for performing this test:

(1) Power source of required capability, range of voltage adjustment, and ability to implement control negotiations (if required).

(2) Data acquisition system capable of capturing the voltage waveform, voltage measurement, voltage ripple measurement, current waveform, current measurement, and current ripple measurement. Measurements shall meet the sampling frequency and accuracy requirements of 4.5.

b. Procedure. The load EUT shall be operated in all pulsed modes of operation for the following steady-state voltage test cases:

(1) Nominal system voltage ± 1 percent, minimal voltage ripple.

(2) Upper limit of the load normal service steady-state voltage range (or greater), minimal voltage ripple.

(3) Lower limit of the load normal service steady-state voltage range (or less), minimal voltage ripple.

For each test case, verify that the EUT does not exceed load maximum current pulse (no control negotiations) and load maximum current rate of change (no control negotiations) without first negotiating with the source. If negotiations have taken place, verify that the EUT has not exceeded the negotiated values for load maximum current pulse and load maximum current rate of change. Record control negotiations and voltage and current waveforms. The frequency content of the voltage and current ripple shall either be directly measured or calculated from the waveforms. Test cases shall be repeated for different sets of source limitations (as documented in the test procedures) to ensure robustness in the negotiation process and to verify that the EUT does not exceed the negotiated values.

5.3.7 Load EMP test.

a. Apparatus. The following apparatus is recommended for performing this test:

(1) Source with sufficient range of capability.

(2) Spike attenuations circuit – if necessary, to ensure at least 95 percent of the injected current flows through the EUT and not the source.

(3) PCI generator in accordance with 5.1.2 and 5.2.6.

(4) Data acquisition system capable of capturing the voltage waveform, voltage measurement, voltage ripple measurement, current waveform, current measurement, and current ripple measurement. Measurements shall meet the sampling frequency and accuracy requirements of 4.5.

b. Procedure. The characteristics of the PCI generator shall be measured in accordance with the manufacturer's instructions and the pulse characteristics shall be in accordance with 5.1.2 and 5.2.6. With power disconnected, the source, spike attenuation circuit (if necessary), PCI generator, measurement equipment, and EUT shall be connected in accordance with the PCI generator's manufacturer's instructions. For each test case, five current pulses shall be applied at the rate of one to two per minute. The following test cases are defined:

(1) Line-to-ground positive conductor, pulsed current into positive conductor.

(2) Line-to-ground positive conductor, pulsed current out of positive conductor.

(3) Line-to-ground negative conductor, pulsed current into negative conductor.

(4) Line-to-ground negative conductor, pulsed current out of negative conductor.

The EUT shall remain operational before, during, and after each application of the series of five current pulses. See 5.2.6 for criteria for required source operability.

5.4 Source requirements.

5.4.1 Source interface. Source interface characteristics and verification methods for demonstrating source operability to the interface characteristics shall be as defined in [table IV](#). Source interface requirements and verification methods shall be as defined in [table V](#).

TABLE IV. Source interface characteristics.

Characteristic	Value: Type I	Verification Method
Nominal system voltages (VDC)	6,000 12,000 18,000	N/A
Source maximum current ripple (rms percent of steady-state current)	10% (see 5.4.2 for frequency limits)	5.5.1
Source maximum pulse (no control negotiation) (A)	See 5.4.5	5.5.5
Source maximum current rate of change (no control negotiation) (A/ms)	See 5.4.5	5.5.5
Source maximum pulse (control negotiation) (A)	See 5.4.5	5.5.5
Source maximum current rate of change (control negotiation) (A/ms)	See 5.4.5	5.5.5

TABLE V. Source interface requirements.

Characteristic	Value: Type I	Verification Method
Source steady-state voltage range: 0 to rated power (percent of nominal system voltage)	90% to 105%	5.5.1
Source steady-state voltage range: current limiting (percent of nominal system voltage)	0% to 90%	5.5.2
Source steady-state voltage tolerance (percent of nominal system voltage)	1%	5.5.1
Source peak voltage ripple (percent of nominal system voltage)	9%	5.5.1
Source maximum steady-state voltage ripple (rms percent of nominal system voltage)	4%	5.5.1
Source maximum steady-state current limit	Rated power divided by $(0.90 \times \text{nominal system voltage})$	5.5.2

5.4.2 Source maximum current ripple. Sources shall be capable of maintaining voltage power quality when supplying current with the specified source maximum current ripple adhering to the following maximum frequency content:

- a. For steady-state DC source currents below 185 amperes and frequencies at or below 10 kilohertz, the CE101 limit for surface ship and submarine applications (DC) as specified in MIL-STD-461.
- b. For steady-state DC source currents at or above 185 amperes and frequencies at or below 10 kilohertz, the CE101 limit for surface ship and submarine applications (DC) as specified in MIL-STD-461 for a load current of 3 amperes relaxed by $20\log(I/3)$ where I is the steady-state DC source current.
- c. For frequency components between 10 kilohertz and 10 megahertz, 0.2 percent of the steady-state DC source current.

5.4.3 Current limiting. If the steady-state bus voltage is within the source steady-state voltage range: 0 to rated power range, the steady-state current provided by the source shall be limited to between 1.0 and 1.05 times the rated power divided by the bus voltage, unless supplying inrush current (see 5.4.4).

If the steady-state bus voltage enters the source steady-state voltage range: current limiting, the source shall regulate the current to a value between 1.0 and 1.1 times the rated power divided by the lower bound of the source steady-state voltage range: 0 to rated power, for a current limiting period of 20 to 25 milliseconds. If at the end of this period the bus voltage has not returned to the source steady-state voltage range: 0 to rated power, the source shall stop providing current to the interface until otherwise commanded by the electric plant control system. If a control system interface is specified (see 6.2) and if, prior to the end of the current limiting period, the control system commands the source to stop providing current to the interface, the source shall stop providing current within 2 milliseconds.

If a control system interface is specified (see 6.2), then during energization of a de-energized bus, the current limiting period may be extended up to a maximum 100 milliseconds by a command from the electric plant control system to facilitate charging of filter capacitors.

5.4.4 Inrush current and current overload capability. Sources shall maintain power quality when supplying loads with inrush current up to the value obtained from [figure 4](#) multiplied by the rated current of the source for a minimum duration of 200 milliseconds.



FIGURE 4. Source maximum inrush current.

When specified (see 6.2), sources shall, in lieu of the requirement in 5.4.3, regulate the current to the specified current overload capability (magnitude and current limiting period) when the bus voltage is within the source steady-state voltage range, current limiting. This overload capability may be employed for fault detection, localization, and isolation.

5.4.5 Current rate of change and pulse support.

- a. The source maximum current pulse (no control negotiation) shall be as specified (see 6.2).
- b. The source maximum current pulse (control negotiation) shall be as specified (see 6.2).
- c. Sources shall be capable of maintaining power quality when subjected to current pulses that do not exceed the source maximum current pulse (no control negotiation).

d. Before a current pulse is applied to a source that exceeds the source maximum current pulse (no control negotiation), the electrical power system control system shall negotiate a source maximum current pulse that shall not exceed the source maximum current pulse (control negotiation) with the source. The protocols for conducting the negotiations shall be as specified (see 6.2), or if not specified, in a manner approved by the Technical Authority. Sources shall be capable of maintaining power quality when subjected to current pulses that do not exceed the negotiated source maximum current pulse.

e. If a source will never be subjected to a current pulse that exceeds the source maximum current pulse (no control negotiation), the source is not required to implement protocols for negotiating the maximum current pulse; the source maximum current pulse (control negotiation) does not apply.

f. Unless otherwise specified (see 6.2), the source maximum current rate of change (no control negotiation) shall be as specified in 5.2.3.

g. Unless otherwise specified (see 6.2), the source maximum current rate of change (control negotiation) shall be as specified in 5.2.3.

h. Sources shall be capable of maintaining power quality when subjected to current pulses and step load changes that do not exceed the source maximum current rate of change (no control negotiation).

i. Before a current pulse or step load change is applied to a source that exceeds the source maximum current rate of change (no control negotiation), the electrical power system control system shall negotiate a source maximum current rate of change that shall not exceed the source maximum current rate of change (control negotiation) with the source. The protocols for conducting the negotiations shall be as specified (see 6.2), or if not specified, in a manner approved by the Technical Authority. Sources shall be capable of maintaining power quality when subjected to current pulses and step load changes that do not exceed the negotiated source maximum current rate of change.

j. If a source will never be subjected to a current pulse or step load change that exceeds the source maximum current rate of change (no control negotiation), the source is not required to implement protocols for negotiating the maximum current rate of change; the source maximum current rate of change (control negotiation) does not apply.

5.4.6 Voltage spikes. Sources shall remain undamaged, shall not suffer any loss of data, shall not require a restart or reboot, and shall remain fully operational before, during, and after being subjected to voltage spikes in accordance with IEC 61000-4-5 using a test level 4 with a 1.2/50-microsecond combination wave generator. See 5.5.5 for the verification method.

5.4.7 EMP protection. Sources shall remain undamaged, shall not suffer any loss of data, shall not require a restart or reboot, and shall remain fully operational before, during, and after being subjected to line-to-ground current pulses from a PCI generator with a waveform specified in 5.1.2, a peak short-circuit current of at least 500 amperes, and a source impedance of at least 60 ohms. See 5.5.6 for the verification method.

5.4.8 Stability. The requirements for small-signal and large-signal stability, including verification requirements, shall be as specified (see 6.2).

5.4.9 Common mode impedance, voltage, and current. Requirements for common mode impedances and requirements for limiting common mode voltages and current, as well as verification requirements, shall be as specified (see 6.2).

5.4.10 Ground fault. Sources shall function normally with a line-to-ground fault on either conductor.

5.4.11 Parallel operation. Sources shall function normally when paralleled with other sources employing load sharing or other power management method(s) as specified (see 6.2). Verification requirements shall be as specified (see 6.2).

5.5 Source verification methods. This section provides source verification procedures to verify compliance to the source interface requirements specified in this standard. For sources verified through testing, the hardware and software of an EUT shall be representative of production units. Verification/test procedure and verification/test report requirements may be tailored as specified (see 6.2) as approved by the Technical Authority. Voltage and current measurements shall be in accordance with 4.5.

5.5.1 Source voltage regulation test.

a. Apparatus. The following apparatus is recommended for performing this test:

(1) Programmable load capable of operation over the source steady-state voltage range: 0 to rated power, with adjustable load up to the source rated power, and the ability to inject source maximum ripple current.

(2) Temperature meter with ± 0.5 °C or better accuracy.

(3) Data acquisition system capable of capturing the voltage waveform, voltage measurement, voltage ripple measurement, current waveform, current measurement, and current ripple measurement. Measurements shall meet the sampling frequency and accuracy requirements of 4.5.

b. Procedure. The EUT shall be operated with the following commanded reference voltage and load test cases:

(1) Nominal system voltage and 8 to 12 percent load with minimal current ripple.

(2) Lower limit of source steady-state voltage range: 0 to rated power and 8 to 12 percent load with minimal current ripple.

(3) Upper limit of source steady-state voltage range: 0 to rated power and 8 to 12 percent load with minimal current ripple.

(4) Nominal system voltage and 95 to 100 percent load with minimal current ripple.

(5) Lower limit of source steady-state voltage range: 0 to rated power and 95 to 100 percent load with minimal current ripple.

(6) Upper limit of source steady-state voltage range: 0 to rated power and 95 to 100 percent load with minimal current ripple.

(7) Nominal system voltage and 8 to 12 percent load with source maximum current ripple.

(8) Lower limit of source steady-state voltage range: 0 to rated power and 8 to 12 percent load with source maximum current ripple.

(9) Upper limit of source steady-state voltage range: 0 to rated power and 8 to 12 percent load with source maximum current ripple.

(10) Nominal system voltage and 95 to 100 percent load with source maximum current ripple.

(11) Lower limit of source steady-state voltage range: 0 to rated power and 95 to 100 percent load with source maximum current ripple.

(12) Upper limit of source steady-state voltage range: 0 to rated power and 95 to 100 percent load with source maximum current ripple.

Unless otherwise specified (see 6.2), for test cases (7) through (12), the current ripple shall consist of a periodic waveform with a fundamental frequency of $1,000 \pm 100$ hertz.

For each test case, once the EUT has achieved temperature stability, the voltage, voltage ripple, current, current ripple, and internal equipment temperatures shall be measured and recorded in measurement windows of at least 6 seconds in duration at a maximum of 1-minute intervals for no less than 5 minutes. The frequency content of the voltage and current ripple shall either be directly measured or calculated from the waveforms. Once the EUT has achieved temperature stability, the EUT shall be verified to function normally.

5.5.2 Source current limit and inrush current test.

a. Apparatus. The following apparatus is recommended for performing this test:

(1) Programmable load capable of operation over the source steady-state voltage range: 0 to rated power, with adjustable load up to the source rated power, and capable of operation over the source steady-state voltage range: constant current with a current up to the current limit specified in 5.4.3.

(2) Capacitor bank (optional).

(3) Temperature meter with ± 0.5 °C or better accuracy.

(4) Data acquisition system capable of capturing the voltage waveform, voltage measurement, voltage ripple measurement, current waveform, current measurement, and current ripple measurement. Measurements shall meet the sampling frequency and accuracy requirements of 4.5.

b. Procedure. The EUT shall be operated with the following test cases:

(1) Load adjusted to result in a voltage within the source steady-state voltage range: constant current. Verify source properly limits current during the current limiting period and then stops providing current.

(2) If a control interface is provided: Load adjusted to result in a voltage within the source steady-state voltage range: constant current. After 10 milliseconds, the control system shall command the source to stop providing current. Verify source properly limits current during the current limiting period and then stops providing current.

(3) Capacitor bank or load programmed to simulate filter capacitor charging with constant dV/dt from 0 volts to nominal system voltage ± 1 percent in 70 to 80 milliseconds with commanded extension of the current limiting period to 85 milliseconds by the control system. Verify source properly limits current while the voltage is in range of the source steady-state voltage range: constant current. Verify source properly transitions to voltage regulation above the upper limit of the source steady-state voltage range: constant current.

(4) Load programmed to simulate a resistive load of between 95 and 100 percent of the rated power at nominal system voltage in parallel with a series combination of a filter capacitor and a filter resistor. The filter resistor (R ohms) value shall be chosen to achieve an inrush current of at least 98 percent of the source maximum inrush current. The filter capacitor value (C farads) shall be chosen such that the inrush current achieves an RC time constant (R multiplied by C) of between 3 milliseconds and 20 milliseconds. The commanded reference voltage of the source shall be set to nominal system voltage. Prior to energization, ensure the filter capacitor is discharged. Upon energization, verify source maintains power quality while supplying inrush current.

For each test case, the voltage waveform, voltage, voltage ripple, current waveform, current, current ripple, and internal equipment temperatures shall be measured and recorded for at least 6 seconds commencing between 200 and 500 milliseconds prior to the application of load. The frequency content of the voltage and current ripple shall either be directly measured or calculated from the waveforms. Measurements shall meet the requirements of 4.5.

5.5.3 Source ground fault test.

a. Apparatus. The following apparatus is recommended for performing this test:

(1) Programmable load capable of operation over the source steady-state voltage range: 0 to rated power, with adjustable load up to the source rated power.

(2) Temperature meter with ± 0.5 °C or better accuracy.

(3) Single pole fused switch for each conductor. The fuse shall be capable of clearing the maximum line-to-line fault current (in case a low impedance already exists within the source between the power system and ground).

(4) Data acquisition system capable of capturing the voltage waveform, voltage measurement, voltage ripple measurement, current waveform, current measurement, and current ripple measurement. Measurements shall meet the sampling frequency and accuracy requirements of 4.5.

b. Procedure. The EUT shall be operated with the following commanded reference voltage, grounding, and load test cases:

(1) Upper limit of source steady-state voltage range: 0 to rated power and 5 to 15 percent load with positive conductor grounded 20 milliseconds after the start of the test.

(2) Upper limit of source steady-state voltage range: 0 to rated power and 90 to 100 percent load with positive conductor grounded 20 milliseconds after the start of the test.

(3) Upper limit of source steady-state voltage range: 0 to rated power and 5 to 15 percent load with negative conductor grounded 20 milliseconds after the start of the test.

(4) Upper limit of source steady-state voltage range: 0 to rated power and 90 to 100 percent load with negative conductor grounded.

For each test case, prior to the start of each test case, the EUT shall be operated without the conductor grounded until the EUT has achieved temperature stability. At the start of the test case when the single pole fused switch is closed for the appropriate conductor, the line-to-line voltage, line-to-ground voltage for each conductor, voltage ripple, current in each conductor, current ripple in each conductor, common-mode current, frequency content of the current ripple, and internal equipment temperatures shall be measured and recorded for at least 100 milliseconds and then in measurement windows of at least 6 seconds in duration at a maximum of 1-minute intervals for at least 5 minutes. The frequency content of the voltage and current ripple shall either be directly measured or calculated from the waveforms. The ground shall then be removed and the test case repeated for each normal operating mode. During testing, the EUT shall be verified to function normally. The EUT fails the test if the fuse associated with one of the fused switches blows.

5.5.4 Source voltage spike test. The source voltage spike test shall be conducted in accordance with the surge immunity test of IEC 61000-4-5 using the test level and wave generator specified in 5.4.6.

5.5.5 Source pulse test.

a. Apparatus. The following apparatus is recommended for performing this test:

(1) Controllable pulse load with capability to implement negotiations. Negotiations may be emulated by an external system if not practical within the load. Pulses shall have a pulse width between 100 milliseconds and 1 second.

(2) Programmable load capable of operation over the source steady-state voltage range: 0 to rated power, with adjustable load up to the source rated power.

(3) Data acquisition system capable of capturing the voltage waveform, voltage measurement, voltage ripple measurement, current waveform, current measurement, and current ripple measurement. Measurements shall meet the sampling frequency and accuracy requirements of 4.5.

b. Procedure. The base load (kW) shall be set equal to 90 percent of the difference between the rated load of the source (kW) minus the appropriate source maximum current pulse (A) multiplied by the nominal system voltage. The source EUT shall be operated in the following test cases:

(1) Nominal system voltage ± 1 percent, programmable load set to the base load, and pulse between 95 and 100 percent of the source maximum current pulse (no control negotiations) and load maximum current rate of change (no control negotiations).

(2) Upper limit of the source normal service steady-state voltage range (or greater), programmable load set to the base load, pulse between 95 and 100 percent of the source maximum current pulse (no control negotiations) and source maximum current rate of change (no control negotiations).

(3) Lower limit of the source normal service steady-state voltage range (or less), programmable load set to the base load, pulse between 95 and 100 percent of the source maximum current pulse (no control negotiations) and source maximum current rate of change (no control negotiations).

If the source is required to implement control negotiations, the source EUT shall be operated in the following additional test cases:

(4) Nominal system voltage ± 1 percent, programmable load set to the base load, pulse between 95 and 100 percent of the source maximum current pulse (control negotiations) and load maximum current rate of change (control negotiations).

(5) Upper limit of the source normal service steady-state voltage range (or greater), programmable load set to the base load, pulse between 95 and 100 percent of the source maximum current pulse (control negotiations) and source maximum current rate of change (control negotiations).

(6) Lower limit of the source normal service steady-state voltage range (or less), programmable load set to the base load, pulse between 95 and 100 percent of the source maximum current pulse (control negotiations) and source maximum current rate of change (control negotiations).

The EUT shall maintain power quality before, during, and following the pulse. Control negotiations (if applicable) and voltage and current waveforms shall be recorded. The frequency content of the voltage and current ripple shall either be directly measured or calculated from the waveforms. The procedure shall be repeated for each operational mode of the EUT.

5.5.6 Source EMP test.

a. Apparatus. The following apparatus is recommended for performing this test:

- (1) Programmable load capable of operation over the source steady-state voltage range: 0 to rated power, with adjustable load up to the source rated power.
- (2) Spike attenuation circuit – if necessary, to ensure at least 95 percent of the injected current flows through the EUT and not the load.
- (3) PCI generator in accordance with 5.1.2 and 5.4.8.
- (4) Data acquisition system capable of capturing the voltage waveform, voltage measurement, voltage ripple measurement, current waveform, current measurement, and current ripple measurement. Measurements shall meet the sampling frequency and accuracy requirements of 4.5.

b. Procedure. The characteristics of the PCI generator shall be measured in accordance with the manufacturer's instructions and the pulse characteristics shall be in accordance with 5.1.2 and 5.4.8. With power disconnected, the programmable load, spike attenuation circuit (if necessary), PCI generator, measurement equipment, and EUT shall be connected in accordance with the PCI generator's manufacturer's instructions. For each test case, five current pulses shall be applied at the rate of one to two per minute. The following test cases are defined:

- (1) Line-to-ground positive conductor, pulsed current into positive conductor, no load.
- (2) Line-to-ground positive conductor, pulsed current out of positive conductor, no load.
- (3) Line-to-ground positive conductor, pulsed current into positive conductor, load set for 95 to 100 percent of the EUT rated power.
- (4) Line-to-ground positive conductor, pulsed current out of positive conductor, load set for 95 to 100 percent of the EUT rated power.
- (5) Line-to-ground negative conductor, pulsed current into negative conductor, no load.
- (6) Line-to-ground negative conductor, pulsed current out of negative conductor, no load.
- (7) Line-to-ground negative conductor, pulsed current into negative conductor, load set for 95 to 100 percent of the EUT rated power.
- (8) Line-to-ground negative conductor, pulsed current out of negative conductor, load set for 95 to 100 percent of the EUT rated power.

The EUT shall remain operational before, during, and after each application of the series of five voltage spikes. See 5.4.7 for criteria for required source operability.

6. NOTES

(This section contains information of a general or explanatory nature that may be helpful, but is not mandatory.)

6.1 Intended use. This standard is intended to be used in designing surface ship MVDC electrical power system sources and loads. This standard applies to integrated power and energy systems where all sources and loads interface to the distribution system via power electronic converters.

The voltage spike and EMP protection requirements enhance the ability of sources and loads to remain undamaged following exposure to EMP. While these requirements reduce the susceptibility of equipment to EMP, they must be incorporated into an overall systems engineering approach to survivability in order for a ship to be capable of continued operation following exposure to EMP. See equipment specifications for additional requirements.

6.2 Acquisition requirements. Acquisition documents should specify the following:

- a. Title, number, and date of this standard.
- b. Verification methods (see 4.2 and 4.3).
- c. Nominal system voltage (see 4.2).
- d. Normal operating modes (see 4.3).

- e. Alternate measurement methods if other than specified (see 4.5).
- f. Sampling rate for common mode currents and voltages (see 4.5.1).
- g. Requirements for deviation requests (see 4.7).
- h. Alternate value for load voltage interruption tolerance time if other than specified (see 5.2.2).
- i. If equipment is designated as MCE (see 5.2.2.a).
- j. If applicable, acceptable low power operating mode of a load during a voltage interruption (see 5.2.2.a).
- k. If applicable, protocols for conducting pulse negotiations (see 5.2.3, 5.2.4, and 5.4.5).
- l. Values for the load (source) maximum current rate of change (control negotiation) and load (source) maximum current rate of change (no control negotiation) if other than specified (see 5.2.3 and 5.4.4).
- m. Values for the load (source) maximum current pulse (control negotiation) and load (source) maximum current pulse (no control negotiation) (see 5.2.4 and 5.4.5).
- n. Stability requirements (see 5.2.7 and 5.4.8).
- o. Requirements for common mode impedance and voltage and current requirements (see 5.2.8 and 5.4.9).
- p. Current ripple frequency limits if other than specified (see 5.2.12).
- q. Requirements for Technical Authority approval of verification/test procedures and verification/test reports derived from tests specified in sections 5.3 and 5.5.
- r. Requirement to perform the pulsed load test (see 5.3).
- s. Voltage ripple waveform and frequency if other than specified (see 5.3.1.b and 5.5.1).
- t. If a source control system interface is required (see 5.4.3).
- u. Requirements for source current overload capability if other than specified (see 5.4.4).
- v. Source load sharing or power management method(s) and parallel operation verification requirements (see 5.4.11).

6.3 Tailoring guidance for contractual application.

- a. Create verification/test procedures by tailoring DI-EMCS-80201 so requirements 1 through 2.2; 2.4.a; 2.6.a, b, e, and f; and 2.7.b, c, and e are used, substituting “interface” for “EMI” and MIL-STD-1399-300-3 as the applicable military standard.
- b. Create verification/test reports by tailoring DI-EMCS-80200 so requirements 1 through 2.2.a, b, f, g, i, m, and o and 2.3 are used, substituting “interface” for “EMI” and MIL-STD-1399-300-3 as the applicable military standard.

6.4 Subject term (key word) listing.

Electrical load
Electrical source
Electrical transients
Inrush current
MVDC
Power quality
Pulsed load
Ripple
Voltage spike

CONCLUDING MATERIAL

Custodians:

Army – AV
Navy – SH

Preparing activity:

Navy – SH
(Project xxxx-xxxx-xxx)

Review activities:

Army – MI, MT
Navy – YD

Civil agency:

GSA – FAS

NOTE: The activities listed above were interested in this document as of the date of this document. Since organizations and responsibilities can change, you should verify the currency of the information above using the ASSIST Online database at <https://assist.dla.mil>.