

3.5" by 2"

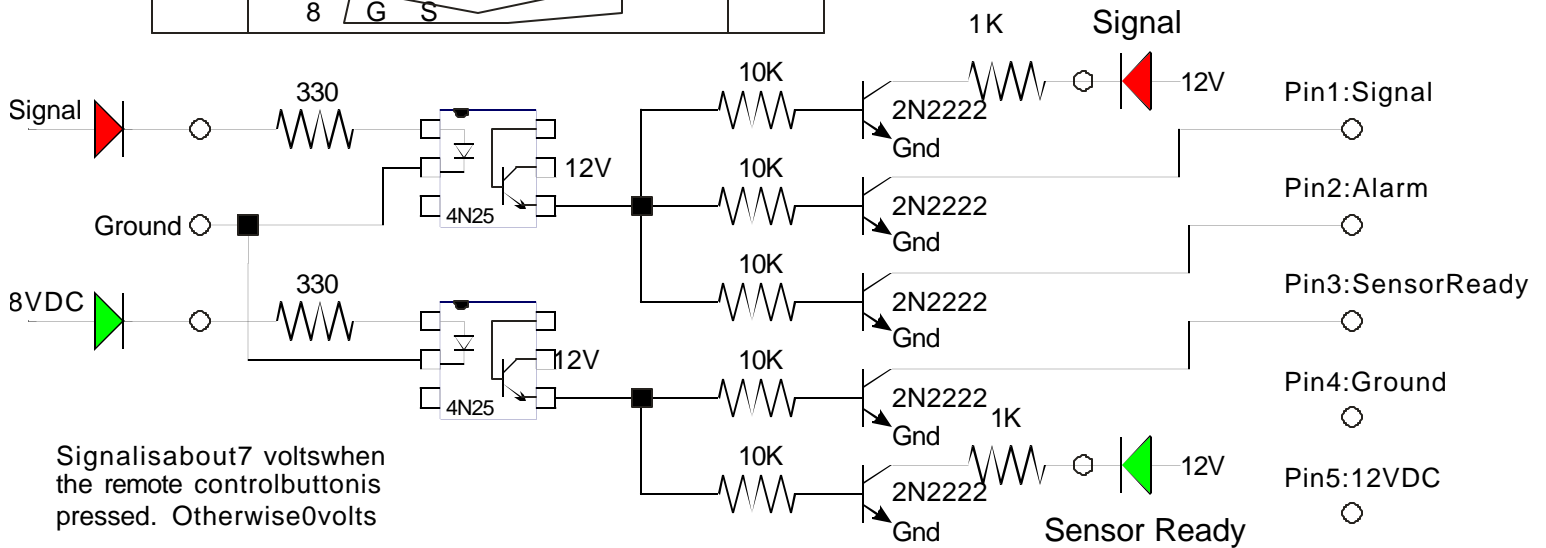

**STANLEY Model 2390 Date 8436 Board 2832-01**

**Away from Edge**

- Pin 1: Orange Pushbutton**
- Pin 2: Blank**
- Pin 3: Red Capacitor and Motor**
- Pin 4: Black Motor (Also Power)**
- Pin 5: Blank**
- Pin 6: Black Power Plug**
- Pin 7: Blue Capacitor and Motor**
- Pin 8: Blank**
- Pin 9: Light Blue Limit Switch**
- Pin 10: Pink Limit Switch**
- Pin 11: Pink Pushbutton**
- Pin 12: Black 120 Volt Light**

# Wireless Interface Norbert Doerry

June 18, 2006  
Rev A: October 28, 2006

Power Cord

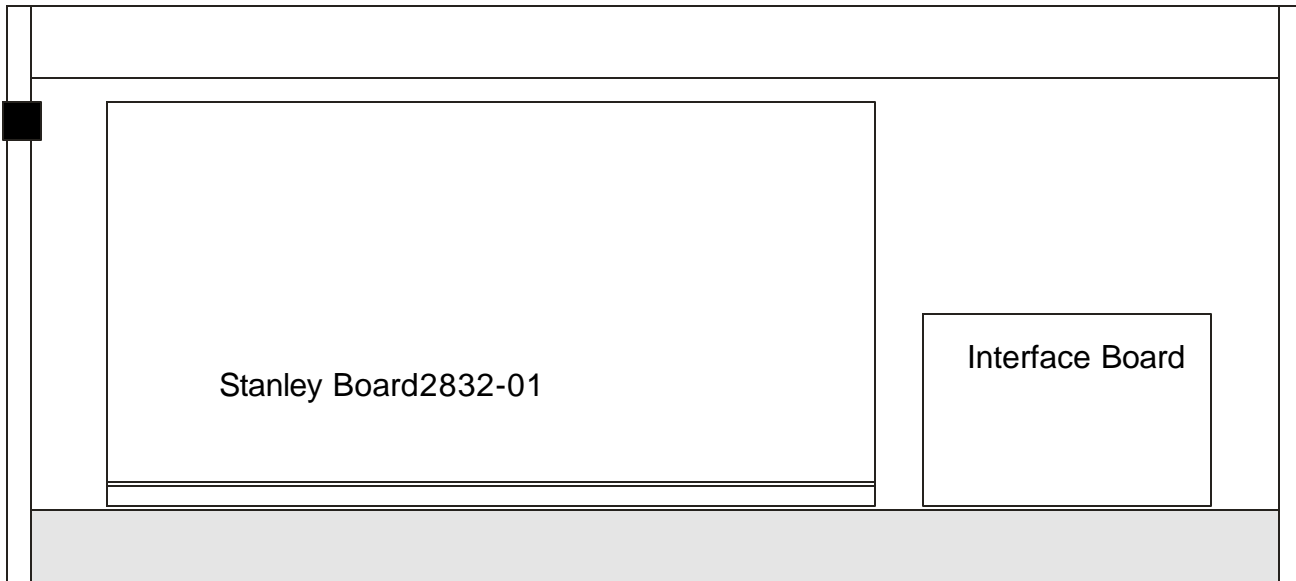

1/2 Scale

# Wireless Interface Norbert Doerry

June 19, 2006  
Rev A: October 28, 2006

1/2 Scale

